

DEVILBISS

SB-EE-25-0481

Iss.04 **CE 0194**

OPERATION MANUAL
MPV-623 AIR-FED VIZOR





DEVILBISS



CE 0194

Operation Manual MPV-623 AIR-FED VIZOR

Important

Read and follow all instructions and Safety Precautions before using this equipment

SAFETY WARNINGS

IMPROPER USE IS DANGEROUS. READ INSTRUCTIONS BEFORE USING

This supplied air respirator is designed to provide a high level of protection in contaminated atmospheres when worn and used correctly. It is not for use in atmospheres immediately dangerous to life or health and if accidentally disconnected or removed the wearer must be able to safely reach clean breathable air supply. The compressed air supply to the respirator must be of breathable quality and conform to BSEN 12021:1998 and relevant National or

local Standards.

THE ACTIVATED CARBON FILTER DOES NOT REMOVE CARBON MONOXIDE OR CARBON DIOXIDE.

THIS DEVICE IS RECOMMENDED WHEN SPRAYING 2 PACK PAINTS AND PAINTS CONTAINING ISOCYANATES.

ITW Finishing Systems and Products reserve the right to modify equipment specification without prior notice.

APPROVAL FOR USE

The MPV supplied air-fed vizor respirator is CE approved under PPE Directive 89/686/EEC. The vizor conforms to European Eye-Protection standard EN166, category F for low energy Impact and liquid splash protection. An MPV supplied air vizor system, correctly fitted and applied by trained personnel in accordance with these instructions, may be used subject to the user determining its suitability, for protection from particles, fumes,

gases and vapours. The respirator should only be used with Devilbiss original components to maintain approval for the system, this includes the compressed air supply hose item 18 (fig1) and hose connectors. INSPEC International Ltd CE approval (Notified body number 0194) 56 Leslie Hough Way, Salford, M6 6AJ, England, United Kingdom.

DESCRIPTION

The MPV supplied air vizor has a lightweight fully adjustable headband. The neck and ears are also protected with a disposable cover. The vizor has a diffused compressed air feed tube. The vizor can be lifted up from the face when the operator is not working in a hazardous area. Two half turn tension knobs adjust the vizor movement. The vizor air feed tube is connected to its associated filter/regulator which is attached at the waistbelt. The preset compressed air pressure regulator maintains a constant flow

of air to the vizor. Manufacturers minimum design flow rate 140 litres/min (4.9 Ft³/min). The disposable activated carbon filter removes odour, oil and vapour. A short hose with connections is supplied for the attachment of a spray gun to the connection provided see fig 1. Two disposable vizor covers and a disposable hood for additional skin protection when used with materials containing chemicals that have harmful effects, are also provided, i.e when spraying 2 pack paints.

SUITABILITY FOR USE

It is the duty of the employer to determine such suitability and in so doing the following factors should be considered bearing in mind that the circumstances of use determine the level of protection provided.

- 1) The respirator must not be used in atmospheres immediately dangerous to life or health; i.e those atmospheres from which it would not be possible to escape without risk to life or health. Such atmospheres include those deficient in oxygen.
- 2) The respirator must not be used in atmosphere where the concentration of contaminant may exceed the allowable exposure limit and it should be noted that at exceptionally high levels of physical work the peak inhalation may exceed the constant flow of supplied air. (See Specification)

3) The wearer must be able to adjust and fit the respirator correctly. The wearer must be trained in the correct wearing and operation of the respirator and understand the limitations of use.

4) The employer should ensure that the respirator, which is intended for light duty service, is suitable and that the appropriate model is selected and that the trailing supply hose will not present a hazard to the wearer or others in the vicinity. Refer to - HSG 53. The selection use and maintenance of respiratory protective equipment (HSE Guide).

5) The employer must provide a suitable management system, to ensure that the respirator is maintained in accordance with the manufacturers instructions. Refer to - BS4275: 1997 Guide to implementing an effective respiratory protective device programme.

SPECIFICATION

**Protection- Assigned Protection Factor
APF=40**

Carbon Filter Life = 1000 HRS.

**NOTE CARBON FILTER HAS A LIMITED
SHELF LIFE.**

**Supply pressure - 3.8 bar (55 lbf/in²) At hose
supply connection (See Fig 1) max 7 bar (100
lbf/in²).**

**Supply hose - Only to be used with Devilbiss
original hose. The manufacturers flow rate is
recommended at a minimum of 140 litres/min
(4.9 SCFM) to the mask. See parts list for
recommended supply hose.**

The **MPV-623** Air Fed Vizion Outfit, comprises of:

MPV-526: Vizion Assembly with ratchet headband, detachable vizion covers neck cover, disposable hood, stowage bag, 2 face cassettes and a hose to connect to MPV-518 waistbelt assembly.

MPV-518: Waistbelt Assembly: An adjustable nylon belt with quick fit buckle. Disposable carbon odour removal filter and pre-set regulator in a moulded housing which is moveable on the belt.

MPV-456 Rubber air hose (1.2 M) with quick detachable fittings to connect spray gun.

INSTALLATION / OPERATION

WARNING: NEVER USE THIS RESPIRATOR IN AN AREA WHERE THE ATMOSPHERE IS IMMEDIATELY HAZARDOUS TO LIFE OR HEALTH. IN AN EMERGENCY THE WEARER MUST BE ABLE TO ESCAPE FROM THE WORK AREA WITHOUT THE NEED OF A RESPIRATOR.

THE AIR SUPPLIED MUST BE OF BREATHABLE QUALITY AND CONFORM TO BSEN 12021:1999 AND THE RELEVANT NATIONAL AND LOCAL STANDARDS.

ONLY USE RECOMMENDED DEVILBISS SUPPLY HOSE

CAUTION: It is essential to site the air intake of the compressor so that the air intake is free from contaminants. The compressed air must be regularly checked for breathable quality.

As a precaution against a supply failure or pressure loss an audible low pressure warning device should be fitted as described under accessories.

NOTE: It is recommended that a new air supply hose item (18) fig1 is used and specially identified for breathing air. In the interest of hygiene each user should have their own face mask and hood.

HOSE LENGTH: Note 10m is the maximum hose length that can be used due to the minimum pressure requirements.

If longer hose length is required a portable coalescing air filter device must be located at the supply end of the 10m hose and be capable of supply pressure of 3.8 Bar (55 lbf/in²) at this point.

DONNING PRODEDURE

WARNING: DO NOT ENTER THE CONTAMINATED AREA UNTIL ITEM (10) IS COMPLETED

1) Connect the air supply hose to the outlet of a coalescing air filter such as a DVFR 2. Do not turn on the air supply.

NOTE: Ensure that the supply hose is of sufficient length to allow the operator to enter and leave the contaminated area without disconnecting or removing the vizor.

2) Check the waistbelt and respirator assemblies ensuring that all parts are in good condition. Replace if damaged.

3) Attach and adjust the waistbelt assembly ensuring that the supply air inlet and spray gun outlet connectors are pointing down.

4) Connect the air supply hose to the waistbelt inlet.

5) Connect the respirator feed tube to the outlet socket on top of the filter assembly.

6) Connect the spray gun air supply hose to QD outlet on the bottom of the filter assembly (if required).

7) Place the vizor assembly on the head and, with the vizor in the open position, adjust the tension knobs.

Ensure that the feed tube is not twisted or kinked and will not interfere with normal movements.

8) Turn on the air supply and check that the air is flowing freely to the inside of the vizor.

9) Adjust the air pressure with the gun (if fitted) triggered to ensure that the minimum supply pressure at the inlet of supply hose is in accordance with the minimum requirements 3.8 bar (55 psi).

10) Before entering the contaminated area, the vizor must be pulled down, so that the material face seal is located under the chin and in contact around its entire periphery, the tension knobs are adjusted so that the vizor is locked in this position.

NOTE: Do not lift or remove the vizor inside the contaminated area. Retreat from the area immediately if any malfunction is suspected or if the warning whistle sounds (if accessory fitted).

REPLACEMENT OF PARTS

DISPOSABLE CARBON FILTER (14):

- 1) Unscrew the three cross head screws holding the regulator (13) to the filter housing (15).
- 2) Remove the spent filter (14) from the filter housing (15) and replace with a complete new

moulded filter cartridge (14)

- 3) Replace the regulator housing and retighten the securing screws.
- 4) Connect to the air supply and ensure correct airflow to the mask before use.

MAINTENANCE

INSPECTION:

- 1) Replace carbon filter see specification for life or sooner if odours are not effectively removed. NOTE CARBON FILTER HAS A LIMITED SHELF LIFE.
- 2) Check security of the hose connections and that hoses and tubes are in good condition. Replace if damaged.

- 3) Visually check the condition and function of all components of the vizor particularly the face seals, head harness. Replace if damaged.
- 4) Check air supply quality on a regular basis see "installation/operation".

CLEANING

- 1) Regularly clean and/or disinfect the face mask and headband assemblies. DO NOT USE PAINT SOLVENTS

Recommended solutions:-

- a) Cleaning: 3ml of liquid detergent to 1 litre of warm water, mix thoroughly.
- b) Disinfectant: 2 ml of Dettol to 1 litre of warm water, mix thoroughly.

Method for cleaning and/or disinfecting:

Use a lint free cloth dampened with the solution and wipe outside and inside of the face mask and headband assemblies. Repeat with a clean lint free cloth dampened with clean luke warm water. Allow to dry naturally, maximum ambient temperature 40°C.

ACCESSORIES

MPV-525: Breathsafe air quality test kit - tests air flow and quality after the waistbelt filter/regulator for carbon monoxide, carbon dioxide, oil mist and water carry-over.

DVFR-2 Filter, regulator and coalescer.

Suitable for 2 operators, this unit provides air filtered to 99.99% at 0.01 micron.

DVCF-1 Filter and coalescer. Suitable for 2 operators, this unit provides air filtered to 99.99% at 0.01 micron.

MPV-405: Low pressure Warning device provides an audible whistle to warn the operator when the air pressure is insufficient to supply the minimum recommended air flow.

Permanently fit to the filter/regulator assembly, remove (16), screw whistle device in place then re-fit connection (16) to whistle inlet.

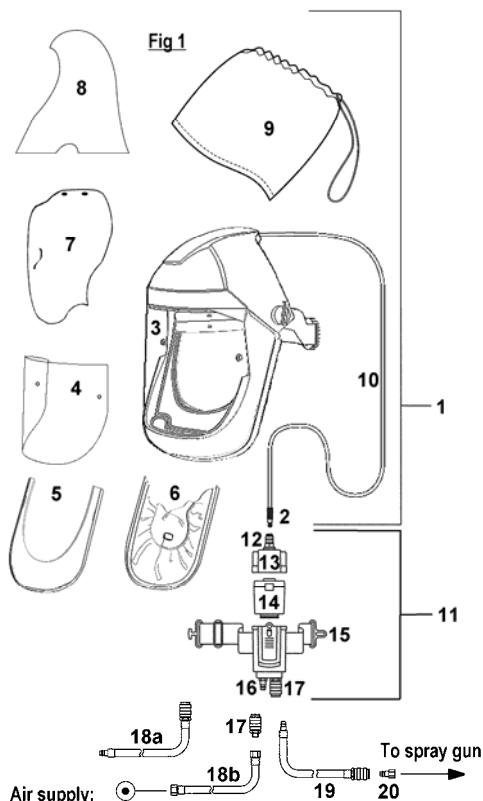

Air supply:
 3.8 Min - 7 Max Bar (55 - 100 psi)
 Breathable quality to BSEN12021:1999
 (Such as from a DVFR2 Filter/Coalescer
 unit, see accessories)

Note Kit quantities do not apply to outfits, see quantities specified in outfit column.

* **NOT PART OF OUTFIT ORDER SEPARATELY**

Use of this Devilbiss supply hose is essential to ensure correct and safe operation of this equipment.

NO	DESCRIPTION	PART NO	QTY MPV-623 OUTFIT	QTY MPV-526 OUTFIT
1	VIZOR ASSEMBLY (REF NOS 2-10)	MPV-526	1	
2	QUICK DETACHABLE STEM	MPV-20	1	1
3	CLEAR VIZOR (KIT OF 5)	MPV-478-K5	1	1
4	VIZOR COVERS (KIT OF 10)	MPV-44-K10	2	2
5	FACE CARTRIDGE—FOAM (KIT OF 5)	MPV-476-K5	1	1
6	FACE CARTRIDGE—TYVEK (KIT OF 5)	MPV-477-K5	1	1
7	NECK COVERS (KIT OF 5)	MPV-24-K5	1	1
8	HOODS (KIT OF 5)	MPV-2-K5	1	1
9	STOWAGE BAG	MPV-458	1	1
10	TUBE AND DIFFUSER ASSY	MPV-457	1	1
11	WAISTBELT ASSEMBLY	MPV-518	1	

NO	DESCRIPTION	PART NO	QTY MPV-623 OUTFIT	QTY MPV-526 OUTFIT
12	QUICK DETACHABLE CONNECTOR	MPV-442	1	
13	REGULATOR AND HOUSING	MPV-455	1	
14	DISPOSABLE FILTER	MPV-22	1	
15	WAISTBELT AND FILTER HOUSING	MPV-519		
16	QUICK DETACHABLE STEM	MPV-10	1	
17	QUICK DETACHABLE CONNECTOR	MPV-424	1	
18	SUPPLY AIR HOSE 5/16" BORE *			
18a	-10M LG M-F QD FITTINGS	H-6085-QD		
18b	-10M LG 1/4" RE-USABLE FITTINGS	H-6065-B-R		
19	GUN HOSE ASSEMBLY	MPV-456	1	
20	QUICK DETACHABLE STEM	MPV-5	1	

ITW Finishing Systems and Products reserve the right to modify equipment specification without prior notice.

ITW Finishing Systems and Products
Ringwood Road,
Bournemouth,
BH11 9LH,
England.
Tel. No. (01202) 571111
Telefax No. (01202) 581940,
Website address <http://www.devilbisseu.com>
<http://www.itwifeuro.com>.

ITW Finishing Systems and Products is a Division of ITW Ltd.
Reg. Office:
Admiral House,
St Leonard's Road,
Windsor,
Berkshire,
SL4 3BL,
UK

Registered in England: No 559693 Vat No 619 5461 24