

Dynamic Surge Suppressor

308178G

ENG

For use with double-diaphragm pumps and low-pressure reciprocating pumps.
For professional use only.

100 psi (0.7 MPa, 7 bar) Maximum Fluid Working Pressure
100 psi (0.7 MPa, 7 bar) Maximum Air Inlet Pressure

Model 224892, Series A
aluminum, with PTFE diaphragm

Model 224893, Series A
aluminum, with buna-N diaphragm

Model 224894, Series C
stainless steel, with PTFE diaphragm

Model 224895, Series C
stainless steel, with buna-N diaphragm



Important Safety Instructions

Read all warnings and instructions in this manual.
Save these instructions.

Table of Contents

| | |
|---------------------------------|----|
| Warnings | 2 |
| Installation | 4 |
| Operation and Maintenance | 7 |
| Troubleshooting | 8 |
| Service | 9 |
| Parts Drawing | 12 |
| Parts Lists | 13 |
| Repair Kits | 14 |
| Dimensional Drawing | 15 |
| Technical Data | 16 |
| Warranty | 18 |
| Graco Phone Number | 18 |

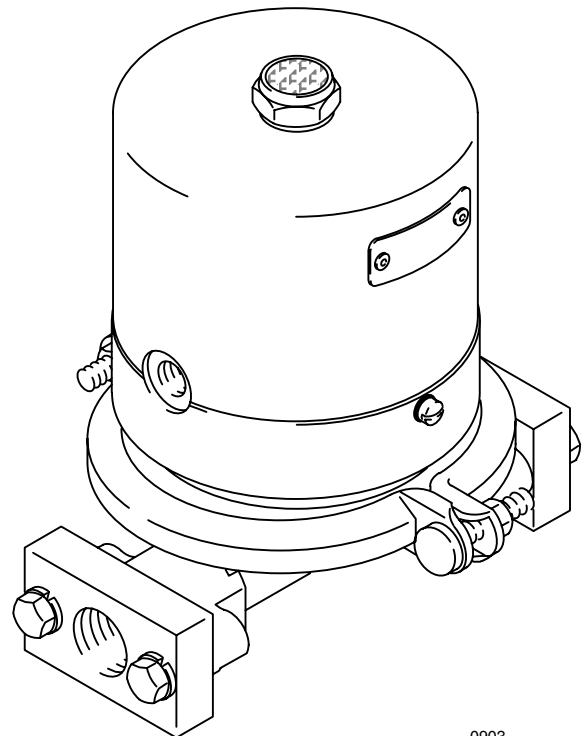

0903

WARNING

Hazard of Using Fluids Containing Halogenated Hydrocarbons

Never use 1,1,1-trichloroethane, methylene chloride, other halogenated hydrocarbon solvents or fluids containing such solvents in aluminum models 224892 or 224893. Such use could result in a chemical reaction, with the possibility of explosion, which could cause death, serious bodily injury, and/or substantial property damage.

Consult your fluid suppliers to ensure that the fluids being used are compatible with aluminum and zinc parts.

Symbols

Warning Symbol



This symbol alerts you to the possibility of serious injury or death if you do not follow the instructions.

Caution Symbol



This symbol alerts you to the possibility of damage to or destruction of equipment if you do not follow the instructions.

WARNING



INSTRUCTIONS

EQUIPMENT MISUSE HAZARD

Equipment misuse can cause the equipment to rupture or malfunction and result in serious injury.

- This equipment is for professional use only.
- Read all instruction manuals, tags, and labels before operating the equipment.
- Use the equipment only for its intended purpose. If you are not sure, call your Graco distributor.
- Do not alter or modify this equipment. Use only genuine Graco parts and accessories.
- Check equipment daily. Repair or replace worn or damaged parts immediately.
- Do not exceed the maximum working pressure of the lowest rated component in your system. See **Technical Data** on page 16.
- Use fluids and solvents that are compatible with the equipment wetted parts. Refer to the **Technical Data** section of all equipment manuals. Read the fluid and solvent manufacturer's warnings.
- Route hoses away from traffic areas, sharp edges, moving parts, and hot surfaces. Do not expose Graco hoses to temperatures above 82°C (180°F) or below -40°C (-40°F).
- Wear hearing protection when operating this equipment.
- Do not lift pressurized equipment.
- Comply with all applicable local, state, and national fire, electrical, and safety regulations.

WARNING



TOXIC FLUID HAZARD

Hazardous fluid or toxic fumes can cause serious injury or death if splashed in the eyes or on the skin, inhaled, or swallowed.

- Know the specific hazards of the fluid you are using.
- Store hazardous fluid in an approved container. Dispose of hazardous fluid according to all local, state and national guidelines.
- Always wear protective eyewear, gloves, clothing and respirator as recommended by the fluid and solvent manufacturer.
- Graco does not manufacture or supply the reactive chemical components that may be used in this equipment and is not responsible for injury or property loss, damage, expense or claims (direct or consequential) that arise from the use of such chemical components.



FIRE AND EXPLOSION HAZARD

Improper grounding, poor ventilation, open flames or sparks can cause a hazardous condition and result in a fire or explosion and serious injury.

- Ground the equipment. See **Grounding** on page 4.
- If there is any static sparking or you feel an electric shock while using this equipment, **stop pumping immediately**. Do not use the equipment until you identify and correct the problem.
- Provide fresh air ventilation to avoid the buildup of flammable fumes from solvents or the fluid being pumped.
- Keep the work area free of debris, including solvent, rags, and gasoline.
- Electrically disconnect all equipment in the work area.
- Extinguish all open flames or pilot lights in the work area.
- Do not smoke in the work area.
- Do not turn on or off any light switch in the work area while operating or if fumes are present.
- Do not operate a gasoline engine in the work area.
- Never use 1.1.1-trichloroethane, methylene chloride, other halogenated hydrocarbon solvents or fluids containing such solvents in pressurized aluminum equipment. Such use could result in a chemical reaction, with the possibility of explosion.



MOVING PARTS HAZARD

Moving parts, such as the air motor piston in the pump, can pinch or amputate your fingers.

- Keep clear of all moving parts when starting or operating the pump.
- Before servicing this surge tank, follow the **Pressure Relief Procedure** on page 4 to prevent the equipment from starting accidentally.

United States Government safety standards have been adopted under the Occupational Safety and Health Act. You should consult these standards—particularly the General Standards, Part 1910.

Installation

System Pressure

The maximum fluid working pressure of this surge suppressor is 100 psi (0.7 MPa, 7 bar) at 100 psi (0.7 MPa, 7 bar) incoming air pressure. **Never** exceed 100 psi (0.7 MPa, 7 bar) fluid or air pressure to the surge suppressor. **Do not** exceed the maximum working pressure of any component or accessory used in the system.

Pressure Relief Procedure

⚠ WARNING

PRESSURIZED EQUIPMENT HAZARD

To reduce the risk of serious bodily injury, including splashing fluid or solvent in the eyes or on the skin, always follow this procedure before you check, adjust, clean, or repair any part of the system.

1. Close the air regulator by turning counterclockwise as far as possible.
2. Disconnect the air supply line to the surge suppressor.
3. Open the dispensing valve, if used.
4. Open the fluid drain valve to relieve all fluid pressure; have a container ready to catch the drainage.

Fluid Compatibility

Be sure all fluids and solvents used are chemically compatible with the wetted parts and non-wetted parts shown in the **Technical Data** section on page 16. Failure of the diaphragm may cause non-wetted parts to be exposed to fluid. Always read the fluid and solvent manufacturer's literature before using them with this equipment.

Grounding

⚠ WARNING

This equipment must be grounded. Read and carefully follow the text of **FIRE AND EXPLOSION HAZARD** on page 3 before operating the surge suppressor.

Static electricity is created by the fluid flowing through the pump and hose. If the equipment is not properly grounded, sparking may occur, and the system may become hazardous. Sparks can ignite fumes from solvents and the fluid being pumped, dust particles,

and other flammable substances, whether you are pumping indoors or outdoors, and can cause a fire or explosion and serious bodily injury and property damage.

If you experience any static sparking or even a slight shock while using this equipment, **stop pumping immediately**. Do not use the system again until the problem has been identified and corrected.

To reduce the risk of static sparking, ground the pump, surge suppressor, and all other equipment used or located in the pumping area. Check your local electrical code for detailed grounding instructions for your area and type of equipment. **Ground all of this equipment:**

- *Pump:* See your separate pump instruction manual.
- *Surge suppressor:* Secure a ground wire (Y) to the surge suppressor with the grounding screw (Z) located on the side of the housing. See Fig. 1. Connect the clamp end of the ground wire to a true earth ground. To order a ground wire and clamp, order Part No. 208950.
- *Air and fluid hoses:* Use only grounded hoses with a maximum of 500 ft (150 m) combined hose length to ensure grounding continuity.
- *Air compressor:* Follow the manufacturer's recommendations.
- *All solvent pails used when flushing:* Follow the local code. *Use only metal pails*, which are conductive. Do not place the pail on a nonconductive surface, such as paper or cardboard, which interrupts the grounding continuity.
- *Fluid supply container:* Follow the local code.

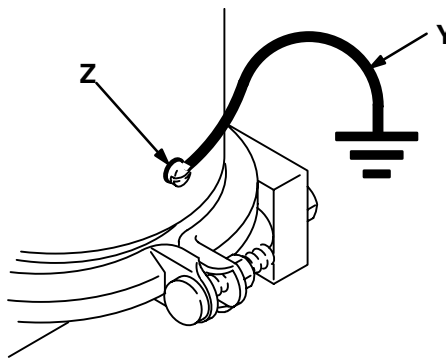

Fig. 1

0942

Installation

The installation shown below is only a guide for selecting and installing system components; it is not an actual system design. Contact your Graco distributor for assistance in planning a system to suit your needs.

KEY

- | | |
|---|---|
| A Surge suppressor | J Air regulator |
| B Air pressure gauge | K Air Filter |
| C Fluid supply line | L Bleed-type master air valve (for accessories) |
| D Fluid outlet line | M Surge suppressor ground wire (required) |
| E Air supply line | N Pump ground wire (required) |
| F Husky 715 pump | |
| G Fluid drain valve | |
| H Bleed-type master air valve (required for pump and surge suppressor) | |

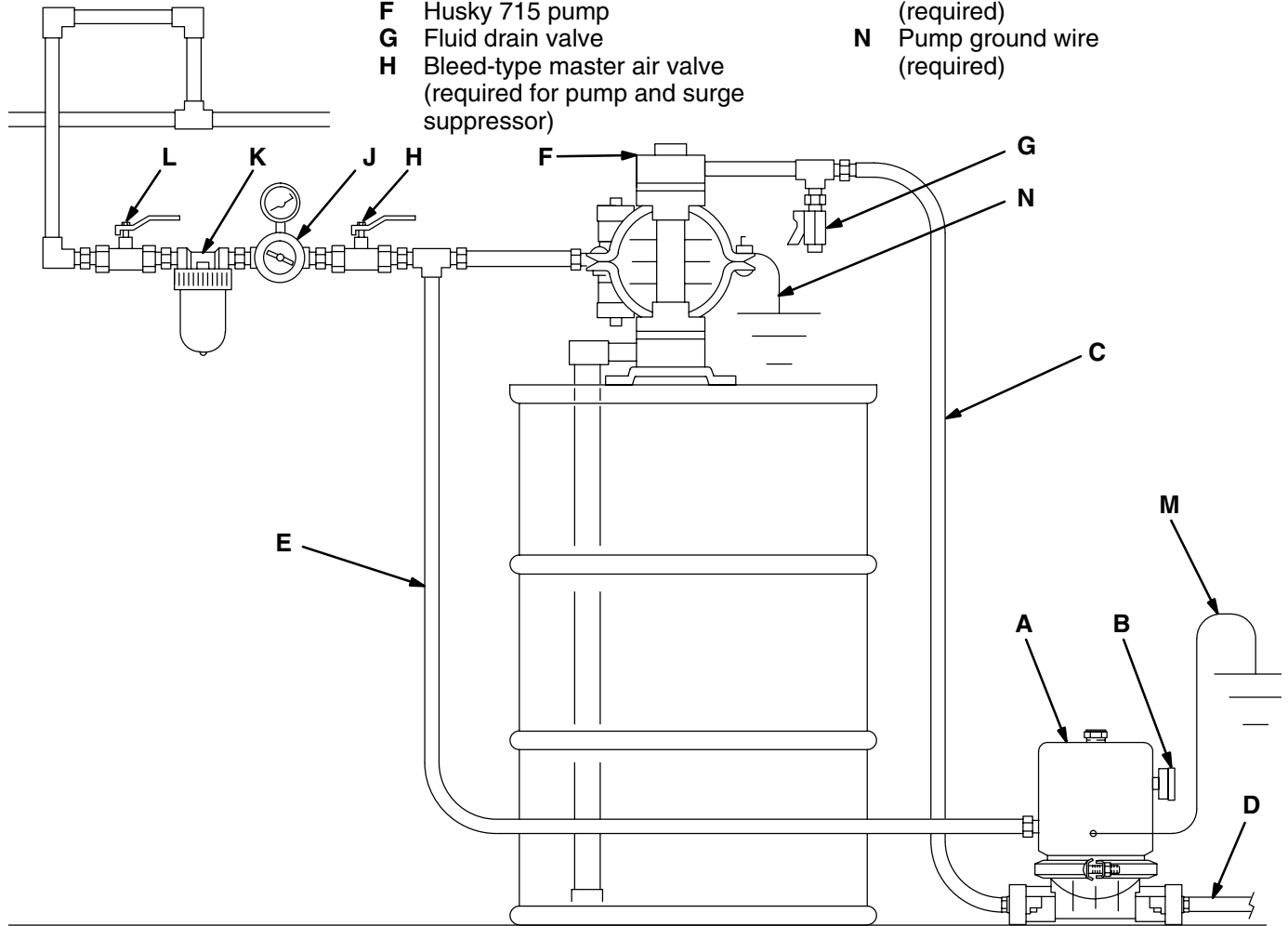

DETAIL A: Venting Exhaust Air to a Remote Container

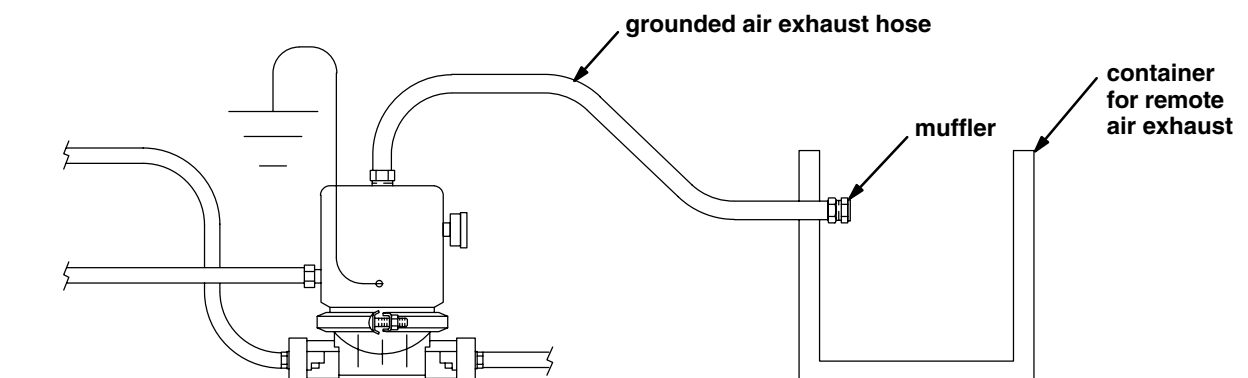

0906

Installation

General Information

The surge suppressor uses air pressure and a diaphragm to maintain a consistent fluid outlet pressure from a double diaphragm or low-pressure reciprocating pump. During normal flow, the suppressor air pressure and fluid pressure are in equilibrium. A sharp increase in fluid pressure causes the air inlet port to open, increasing air pressure on the diaphragm and returning the system to equilibrium. Conversely, a sharp decrease in fluid pressure causes the air exhaust port to open, decreasing air pressure on the diaphragm and allowing the system to return to equilibrium.

Installation

1. Read this entire manual before installing or operating the surge suppressor.
2. The surge suppressor fluid inlet must be connected to the pump's fluid outlet. **If the pump is aluminum or steel**, the surge suppressor may be plumbed directly to the outlet, using 3/4 npt fittings. **If the pump is acetal or polypropylene**, place the surge suppressor on the floor or some other solid, level surface near the pump, and connect the surge suppressor inlet to the pump outlet with a 3/4" ID hose and 3/4 npt fittings.

CAUTION

Do not plumb the surge suppressor directly onto the fluid outlet of an acetal or polypropylene pump. Those pumps cannot support the weight of the suppressor and will suffer damage or rupture.

3. Connect an air line from the pump's air regulator to the air inlet of the surge suppressor. In systems using a 1:1 ratio pump, the air pressure supplied to the suppressor will be the same as that supplied to the pump.
4. Use a compatible, liquid thread sealant on all male threads. Tighten all connections firmly to avoid air or fluid leaks.

CAUTION

To avoid pump damage, do not overtighten the fittings to the pump.

Air Exhaust Ventilation

WARNING

Be sure to read **TOXIC FLUID HAZARD** and **FIRE AND EXPLOSION HAZARD** on page 3, before operating this equipment.

Be sure the system is properly ventilated for your type of installation. When pumping flammable or hazardous fluids, you must vent the surge suppressor exhaust air to a safe place, away from people, animals, food handling areas, and all sources of ignition. If the diaphragm ruptures, the fluid will be exhausted along with the air. Place a container at the end of the air exhaust line to catch the fluid. See **Detail A** on page 5.

The minimum size for the air exhaust hose is 3/8 in. (10 mm) ID x 15 ft (4.6 m). If a longer hose is required, use a larger diameter hose.

1. Remove the muffler from the surge suppressor exhaust port. Install an exhaust hose in the exhaust port, and connect the muffler to the other end of the hose. Avoid sharp bends or kinks in the hose. See **Detail A** on page 5.
2. Place a container at the end of the air exhaust line to catch fluid in case the diaphragm ruptures.

WARNING

Never operate the surge suppressor without the muffler or an air exhaust line installed in the air exhaust port. If the air exhaust port is left open and the diaphragm shaft works loose from the bolt, the shaft could be propelled out of the housing, causing injury.

Operation and Maintenance

Operating the Surge Suppressor

1. Be sure the system is properly grounded. Read and follow **FIRE AND EXPLOSION HAZARD**, on page 3.
2. Check all fittings to be sure they are tight. Be sure to use a compatible liquid thread sealant on all male threads, and do not overtighten the fittings into the pump.
3. Check that the muffler or air exhaust line is securely connected to the air exhaust port on the top of the housing.

WARNING

Never operate the surge suppressor without the muffler or an air exhaust line installed in the air exhaust port. If the air exhaust port is left open and the diaphragm shaft works loose from the bolt, the shaft could be propelled out of the housing, causing injury.

4. Start the pump as explained in your separate pump manual. In systems using a 1:1 ratio pump, the air pressure supplied to the suppressor will be the same as that supplied to the pump.
5. Allow the pump to cycle slowly until all air is pushed out of the surge suppressor and lines, and the pump is primed. The system is now ready for normal operation.

NOTES:

When using a pump with a ratio greater than 1:1, the air pressure supplied to the surge suppressor and the air pressure supplied to the pump must be at the same ratio as the pump to prevent overpressurization of the surge suppressor. See the following examples.

- In a system using a 2:1 ratio pump, air pressure supplied to the surge suppressor should be **twice** as high as air pressure to the pump. If the air pressure supplied to the pump is 50 psi (0.34 MPa, 3.4 bar), you should supply 100 psi (0.7 MPa, 7 bar) air pressure to the surge suppressor.
- In a system using a 4:1 ratio pump, air pressure supplied to the surge suppressor should be **four times** as high as air pressure to the pump. If the air pressure supplied to the pump is 25 psi (0.17 MPa, 1.7 bar), you should supply 100 psi (0.7 MPa, 7 bar) air pressure to the surge suppressor.

WARNING

To prevent overpressurization of the surge suppressor, **never** exceed 100 psi (0.7 MPa, 7 bar) fluid inlet pressure or 100 psi (0.7 MPa, 7 bar) air inlet pressure. In systems using pumps with a ratio greater than 1:1, reduce the air inlet pressure to the pump as necessary to keep the fluid and air inlet pressures to the surge suppressor within these limits.

CAUTION

In systems using pumps with a ratio greater than 1:1, fluid may escape into the surge suppressor air line and contaminate the air supply if the diaphragm fails. Installation of a check valve in the air line will prevent fluid contamination of the air line.

Flushing the System

Flush the system regularly, using a compatible solvent. Do not allow fluid to dry in the pump or surge suppressor. Always flush the pump and surge suppressor before storing them for any length of time.

Place the pump suction tube in the solvent container. Run the pump long enough to thoroughly clean it, the surge suppressor, hoses, and any guns or valves used in the system. Close the pump air regulator. Remove the suction hose from the solvent.

Shutdown

Remove the suction hose from the fluid container and run the pump until the fluid is forced out of the system. Then shut off the air supply immediately.

Troubleshooting

WARNING

To reduce the risk of serious injury whenever you are instructed to relieve pressure, always follow the **Pressure Relief Procedure** on page 4.

Relieve the pressure.

Check all possible problems and causes before disassembling the pump or surge suppressor.

| PROBLEM | CAUSE | SOLUTION |
|--|--|---|
| Surge suppressor operates erratically | Clogged air line or air inlet | Inspect; clear. |
| | Air line connected to pressure gauge port | Connect air line to air inlet (see page 11). |
| | Clogged fluid supply line, fluid inlet or fluid outlet | Inspect; clear. |
| | Diaphragm (13 or 21†) ruptured | Replace. See page 9. |
| | Unbalanced air pressures between pump and surge suppressor | Ratio of air inlet pressure to surge suppressor and air inlet pressure to pump must be the same as pump ratio, but air pressure to surge suppressor must never exceed 100 psi (0.7 MPa, 7 bar). See page 7. |
| Air bubbles in fluid | Fluid supply line loose | Tighten. |
| | Diaphragm (13 or 21†) ruptured | Replace. See page 9. |
| | Manifold o-rings (16) leaking | Replace. See page 10. |
| Fluid in exhaust air | Diaphragm (13 or 21†) ruptured | Replace. See page 9. |
| | Diaphragm plates (12 or 32) loose or damaged | Tighten or replace. See page 9. |
| | Damaged shaft (11) or shaft o-rings (19) | Replace. See page 9. |
| Pump leaks air or fluid from cover (7) | V-clamp (6) is loose | Tighten V-clamp. See page 9. |

† Ref. No. 21, the PTFE diaphragm, is used only in Surge Suppressor Models 224892 and 224894.

Service

Servicing the Shaft O-Rings

1. Relieve the pressure.

WARNING

To reduce the risk of serious injury whenever you are instructed to relieve pressure, always follow the **Pressure Relief Procedure** on page 4.

2. Place a container under the surge suppressor, disconnect the hoses, and turn the surge suppressor on end to drain the fluid.
3. Remove the v-clamp (6). See the **Parts Drawing** on page 12.
4. Separate the housing (8) from the cover (7) to expose the diaphragm and shaft assembly. Pull the diaphragm and shaft out of the housing. See Fig. 2.
5. Remove the three o-rings (19) from the shaft (11).
6. Lubricate the three new o-rings (19*) with lithium-based grease and install them in the grooves on the shaft.
7. Lubricate the inner diameter of the housing (8) with lithium-based grease. Slide the shaft and diaphragm assembly into the housing (8). Place the cover (7) on the housing (8).
8. Position the clamp (6) around the housing (8) and cover (7). Apply thread lubricant to the threads of the v-clamp, secure with the nuts, and torque to 6 to 10 ft-lb (1.4 to 13.6 N.m). See the **Parts Drawing** on page 12.

Servicing the Diaphragm and Shaft

NOTE: Diaphragm Repair Kits are available. See page 14. Parts included in the kits are marked with asterisks. The kits include some parts which are not used on the surge suppressor. Use all the applicable parts in the kit for the best results.

1. Relieve the pressure.

WARNING

To reduce the risk of serious injury whenever you are instructed to relieve pressure, always follow the **Pressure Relief Procedure** on page 4.

2. Place a container under the surge suppressor, disconnect the hoses, and turn the surge suppressor on end to drain the fluid.
3. Remove the v-clamp (6). See the **Parts Drawing** on page 12.
4. Separate the housing (8) from the cover (7) to expose the diaphragm and shaft assembly. Pull the diaphragm and shaft out of the housing. See Fig. 2.
5. Hold the bolt (14) steady with a wrench. Wrap a rag around the shaft (11) to protect it, then unscrew the shaft from the bolt using locking pliers. Remove the nut (31), upper diaphragm plate (32*), diaphragm (13), PTFE diaphragm plate (32*), diaphragm (13), PTFE diaphragm plate (12), and o-ring (15) from the bolt. Clean and inspect all parts for wear or damage.

Service

6. Place the o-ring (15*) on the bolt (14). Install the lower diaphragm plate (12), with the flat side facing down.
7. Install the diaphragm (13**), making certain that the side marked AIR SIDE is facing up on the bolt. *On Models 224892 and 224894 only*, install the PTFE diaphragm (21**) first, then the backup diaphragm (13**).
8. Install the upper diaphragm plate (32*) with the flat side facing up. Apply thread sealant to the bolt (14). Hold the bolt steady with a wrench, and screw the nut (31) onto the bolt (14). Torque to 5 to 7 ft-lb (7 to 10 N-m).
9. Wrap the shaft (11) with a rag to protect it, and use locking pliers to screw the shaft onto the bolt (14). Torque to 10 to 15 in-lb (1.1 to 1.7 N-m).
10. Lubricate the inner diameter of the housing (8) with lithium-based grease. Slide the shaft and diaphragm assembly into the housing (8). Place the cover (7) on the housing (8).
11. Position the clamp (6) around the housing (8) and cover (7). Apply thread lubricant to the threads of the v-clamp, secure with the nuts, and torque to 6 to 10 ft-lb (8 to 14 N.m). See the **Parts Drawing** on page 12.

Servicing the Fluid Inlet and Outlet

NOTE: Repair Kits are available to service the internal parts of the fluid inlet and outlet. See page 14 for ordering information. Parts included in the kits are marked with three asterisks, for example (16***). The kits include some parts which are not used on the surge suppressor. Use all the applicable parts in the kit for the best results.

1. **Relieve the pressure.**

WARNING

To reduce the risk of serious injury whenever you are instructed to relieve pressure, always follow the **Pressure Relief Procedure** on page 4.

2. Place a container under the surge suppressor, disconnect the hoses, and turn the surge suppressor on end to drain the fluid.
3. Remove the bolts (2), lockwashers (3), and nuts (1) holding one manifold (9) to the cover (7). Repeat for the other side. See Fig. 2.
4. Pull the two o-rings (16), guide (18) and stop (17) out of the cover (7). Repeat for the other side. Clean and inspect all parts for wear or damage.
5. Push one o-ring (16***) all the way into the cavity of the cover (7). Install the stop (17***) with the beveled side facing inward. Install the guide (18**) with the flat end facing inward, then install the second o-ring (16***) around the outer edge of the guide. Repeat for the other side.
6. Install the manifold (9) on the cover (7) with the chamfer facing outward. Secure with the bolts (2), lockwashers (3), and nuts (1). Torque to 3 to 6 ft-lb (4 to 8 N.m). Repeat for the other side.

Service

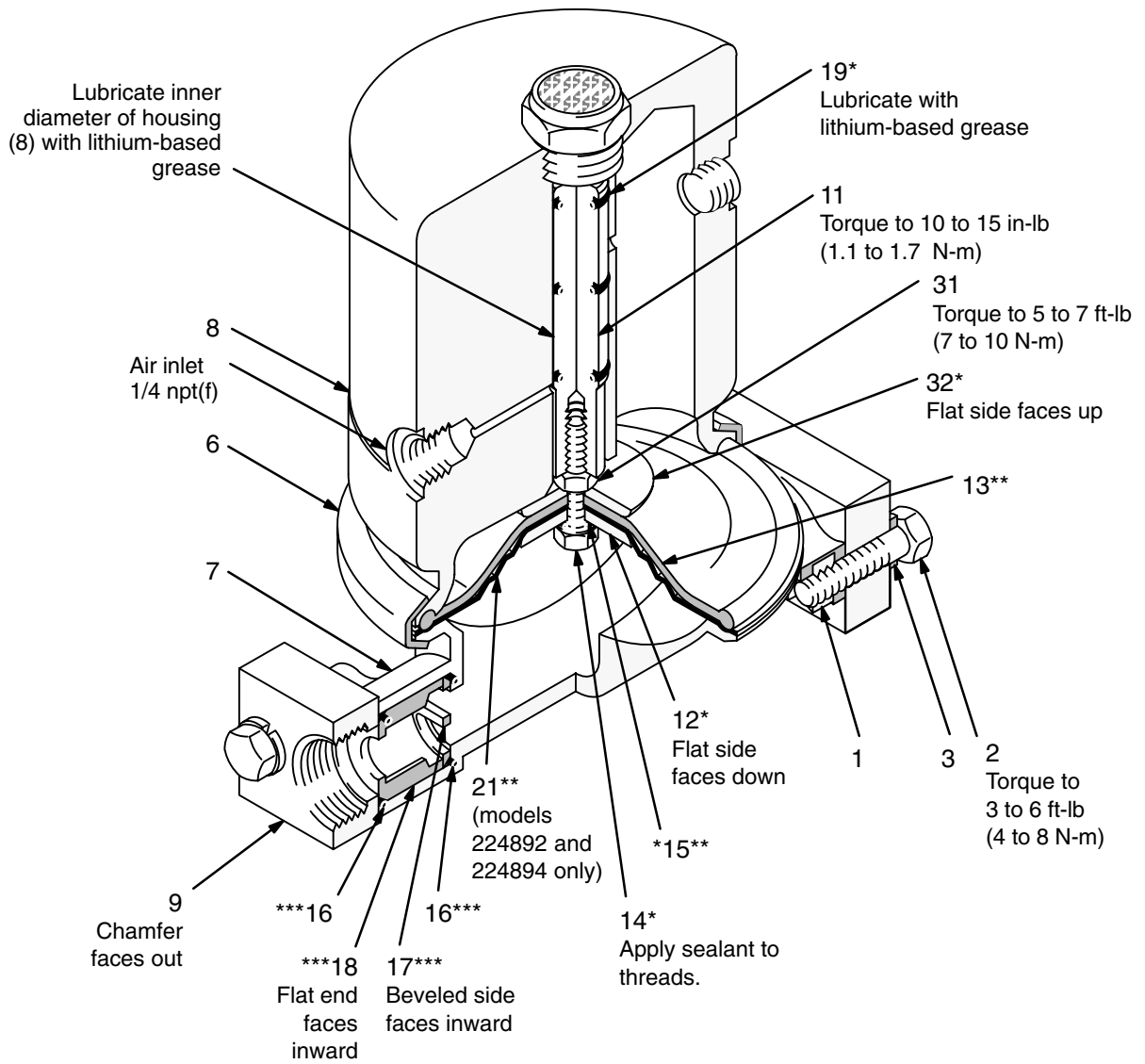

Fig. 2

0905

Parts Drawing

Model 224892, Series A, aluminum surge suppressor with PTFE diaphragm

Model 224893, Series A, aluminum surge suppressor with buna-N diaphragm

Model 224894, Series C, stainless steel surge suppressor with PTFE diaphragm

Model 224895, Series C, stainless steel surge suppressor with buna-N diaphragm

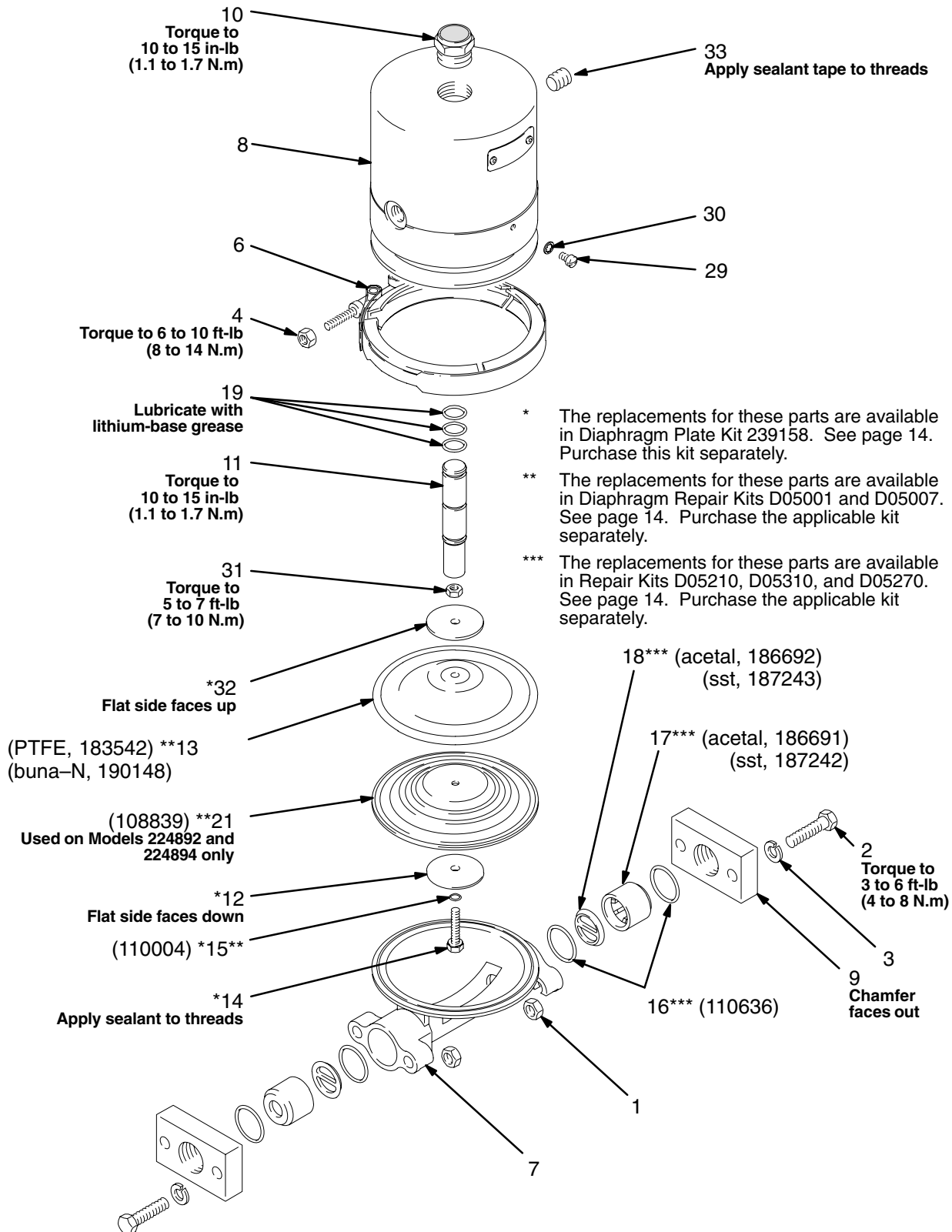

05476

Parts Lists

Model 224892, Series A
aluminum surge suppressor with PTFE diaphragm

Model 224893, Series A
aluminum surge suppressor with buna-N diaphragm

| Ref No. | Part No. | Description | Qty |
|---------|-----------|---|-----|
| 1 | 100307 | NUT, hex; 3/8-16 unc-2b | 4 |
| 2 | 100003 | BOLT, cap, hex hd; 3/8-16 unc-2a x 1.5" long | 4 |
| 3 | 111203 | LOCKWASHER; 3/8" size | 4 |
| 4 | 112499 | NUT, hex; 5/16 18-8; silver-plate sst | 1 |
| 6 | 189540 | V-CLAMP; sst | 1 |
| 7 | 185622 | COVER; aluminum | 1 |
| 8 | 187476 | HOUSING; aluminum | 1 |
| 9 | 187477 | MANIFOLD; aluminum | 2 |
| 10 | 111530 | MUFFLER | 1 |
| 11 | 187475 | SHAFT; acetal | 1 |
| 12 | 191837* | PLATE, diaphragm, fluid side; sst | 1 |
| 13 | 183542** | DIAPHRAGM, backup; polyurethane; <i>used on Model 224892 only</i> | 1 |
| | 190148** | DIAPHRAGM; buna-N; <i>used on Model 224893 only</i> | 1 |
| 14 | 113901* | SCREW, cap, hex hd; 1/4-20 unc-2a x 1.25" long; sst | 1 |
| 15 | *110004** | O-RING; PTFE | 1 |
| 16 | 110636*** | O-RING; PTFE; <i>used on Model 224892 only</i> | 4 |
| | 110636*** | O-RING; buna-N; <i>used on Model 224893 only</i> | 4 |
| 17 | 186692*** | STOP, ball; acetal | 2 |
| 18 | 186691*** | GUIDE, ball; acetal | 2 |
| 19 | 111532 | O-RING; buna-N | 3 |
| 21 | 108839** | DIAPHRAGM; PTFE; <i>used on Model 224892 only</i> | 1 |
| 29 | 100264 | SCREW, machine, pan hd; 10-24 unc-2a x 5/16" long | 1 |
| 30 | 100718 | LOCKWASHER, int tooth; no. 10 | 1 |
| 31 | 102025 | NUT, hex; 1/4-20; sst | 1 |
| 32 | 191741* | PLATE, diaphragm, air side; SST | 1 |
| 33 | 100721 | PLUG, pipe, headless; 1/4 npt | 1 |

* The replacements for these parts are available in Diaphragm Plate Kit 239158. See page 14. Purchase the kit separately.

** The replacements for these parts are available in Diaphragm Repair Kits D05001 and D05007. See page 14. Purchase the applicable kit separately.

*** The replacements for these parts are available in Repair Kits D05210, D05310, and D05270. See page 14. Purchase the applicable kit separately.

Model 224894, Series C
stainless steel surge suppressor with PTFE diaphragm

Model 224895, Series C
stainless steel surge suppressor with buna-N diaphragm

| Ref No. | Part No. | Description | Qty |
|---------|-----------|---|-----|
| 1 | 100307 | NUT, hex; 3/8-16 unc-2b | 4 |
| 2 | 100003 | BOLT, cap, hex hd; 3/8-16 unc-2a x 1.5" long | 4 |
| 3 | 111203 | LOCKWASHER; 3/8" size | 4 |
| 4 | 112499 | NUT, hex; 5/16 18-8; silver-plate sst | 1 |
| 6 | 189540 | V-CLAMP; sst | 1 |
| 7 | 187241 | COVER; stainless steel | 1 |
| 8 | 187476 | HOUSING; aluminum | 1 |
| 9 | 187564 | MANIFOLD; stainless steel | 2 |
| 10 | 111530 | MUFFLER | 1 |
| 11 | 187475 | SHAFT; acetal | 1 |
| 12 | 191837* | PLATE, diaphragm, fluid side; sst | 1 |
| 13 | 183542** | DIAPHRAGM, backup; polyurethane; <i>used on Model 224894 only</i> | 1 |
| | 190148** | DIAPHRAGM; buna-N; <i>used on Model 224895 only</i> | 1 |
| 14 | 113901* | SCREW, cap, hex hd; 1/4-20 unc-2a x 1.25" long; sst | 1 |
| 15 | *110004** | O-RING; PTFE | 1 |
| 16 | 110636*** | O-RING; PTFE; <i>used on Model 224894 only</i> | 4 |
| | 110636*** | O-RING; buna-N; <i>used on Model 224895 only</i> | 4 |
| 17 | 187243*** | STOP, ball; stainless steel | 2 |
| 18 | 187242*** | GUIDE, ball; stainless steel | 2 |
| 19 | 111532 | O-RING; buna-N | 3 |
| 21 | 108839** | DIAPHRAGM; PTFE; <i>used on Model 224894 only</i> | 1 |
| 29 | 100264 | SCREW, machine, pan hd; 10-24 unc-2a x 5/16" long | 1 |
| 30 | 100718 | LOCKWASHER, int tooth; no. 10 | 1 |
| 31 | 102025 | NUT, hex; 1/4-20; sst | 1 |
| 32 | 191741* | PLATE, diaphragm, air side; SST | 1 |
| 33 | 100721 | PLUG, pipe, headless; 1/4 npt | 1 |

* The replacements for these parts are available in Diaphragm Plate Kit 239158. See page 14. Purchase the kit separately.

** The replacements for these parts are available in Diaphragm Repair Kits D05001 and D05007. See page 14. Purchase the applicable kit separately.

*** The replacements for these parts are available in Repair Kits D05210, D05310, and D05270. See page 14. Purchase the applicable kit separately.

Repair Kits

Repair Kits must be purchased separately.
Use only genuine Graco parts and accessories.

The Ref. No. shown in the kits below correspond to the reference numbers used in the **Parts List** on page 13. For the best results, use all the parts in the kit, even if the old parts still look good.

PTFE Diaphragm Kit D05001

For Models 224892 and 224894. Includes enough parts to service the surge suppressor twice.

| Ref No. | Part No. | Description | Qty. |
|---------|----------|---------------------------------|------|
| 13 | 183542 | DIAPHRAGM, backup; polyurethane | 2 |
| 15 | 110004 | PACKING, o-ring | 2 |
| 16 | 110636 | PACKING, o-ring | 8 |
| ‡ | 191779 | BEARING; acetal | 2 |
| ‡ | 113704 | PACKING, o-ring; FKM | 2 |
| 21 | 108839 | DIAPHRAGM; PTFE | 2 |

‡ These parts are not used with the surge suppressor.

Buna-N Diaphragm Kit D05007

For Models 224893 and 224895. Includes enough parts to service the surge suppressor twice.

| Ref No. | Part No. | Description | Qty. |
|---------|----------|----------------------|------|
| 13 | 190148 | DIAPHRAGM; buna-N | 2 |
| 15 | 110004 | PACKING, o-ring | 2 |
| 16 | 110636 | PACKING, o-ring | 8 |
| ‡ | 191779 | BEARING; acetal | 2 |
| ‡ | 113704 | PACKING, o-ring; FKM | 2 |

‡ These parts are not used with the surge suppressor.

PTFE Ball Repair Kit D05210

For Model 224892 only. Includes enough parts to service the surge suppressor twice.

| Ref No. | Part No. | Description | Qty. |
|---------|----------|---------------------------|------|
| 15 | 110004 | PACKING, o-ring | 2 |
| 16 | 110636 | O-RING; PTFE | 8 |
| 17 | 186691 | GUIDE, ball; black acetal | 4 |
| 18 | 186692 | STOP, ball; black acetal | 4 |
| ‡ | 108639 | BALL; 0.75"; PTFE | 4 |

‡ These parts are not used with the surge suppressor.

Buna-N Ball Repair Kit D05270

For Model 224893 only. Includes enough parts to service the surge suppressor twice.

| Ref No. | Part No. | Description | Qty. |
|---------|----------|---------------------------|------|
| 15 | 110004 | PACKING, o-ring | 2 |
| 16 | 110636 | PACKING, o-ring | 8 |
| 17 | 186691 | GUIDE, ball; black acetal | 4 |
| 18 | 186692 | STOP, ball; black acetal | 4 |
| ‡ | 108944 | BALL; 0.75"; buna-N | 4 |

‡ These parts are not used with the surge suppressor.

PTFE Ball Repair Kit D05310

For Model 224894 only. Includes enough parts to service the surge suppressor twice.

| Ref No. | Part No. | Description | Qty. |
|---------|----------|------------------------------|------|
| 15 | 110004 | PACKING, o-ring | 2 |
| 16 | 110636 | O-RING; PTFE | 8 |
| 17 | 187242 | GUIDE, ball; stainless steel | 4 |
| 18 | 187243 | STOP, ball; stainless steel | 4 |
| ‡ | 108639 | BALL; 0.75"; PTFE | 4 |

‡ These parts are not used with the surge suppressor.

Buna-N Ball Repair Kit D05370

For Model 224895 only. Includes enough parts to service the surge suppressor twice.

| Ref No. | Part No. | Description | Qty. |
|---------|----------|------------------------------|------|
| 15 | 110004 | PACKING, o-ring | 2 |
| 16 | 110636 | PACKING, o-ring | 8 |
| 17 | 187242 | GUIDE, ball; stainless steel | 4 |
| 18 | 187243 | STOP, ball; stainless steel | 4 |
| ‡ | 108944 | BALL; 0.75"; buna-N | 4 |

‡ These parts are not used with the surge suppressor.

‡ These parts are not used with the surge suppressor.

Diaphragm Plate Kit 239158

For all models.

| Ref No. | Part No. | Description | Qty. |
|---------|----------|--|------|
| 12 | 191837 | PLATE, diaphragm, fluid side | 1 |
| 14 | 113901 | SCREW, flange, hex-head; 1/4-20 x 1.25 | 1 |
| 15 | 110004 | PACKING, o-ring; PTFE | 1 |
| 32 | 191741 | PLATE, diaphragm, air side | 1 |

Dimensional Drawing

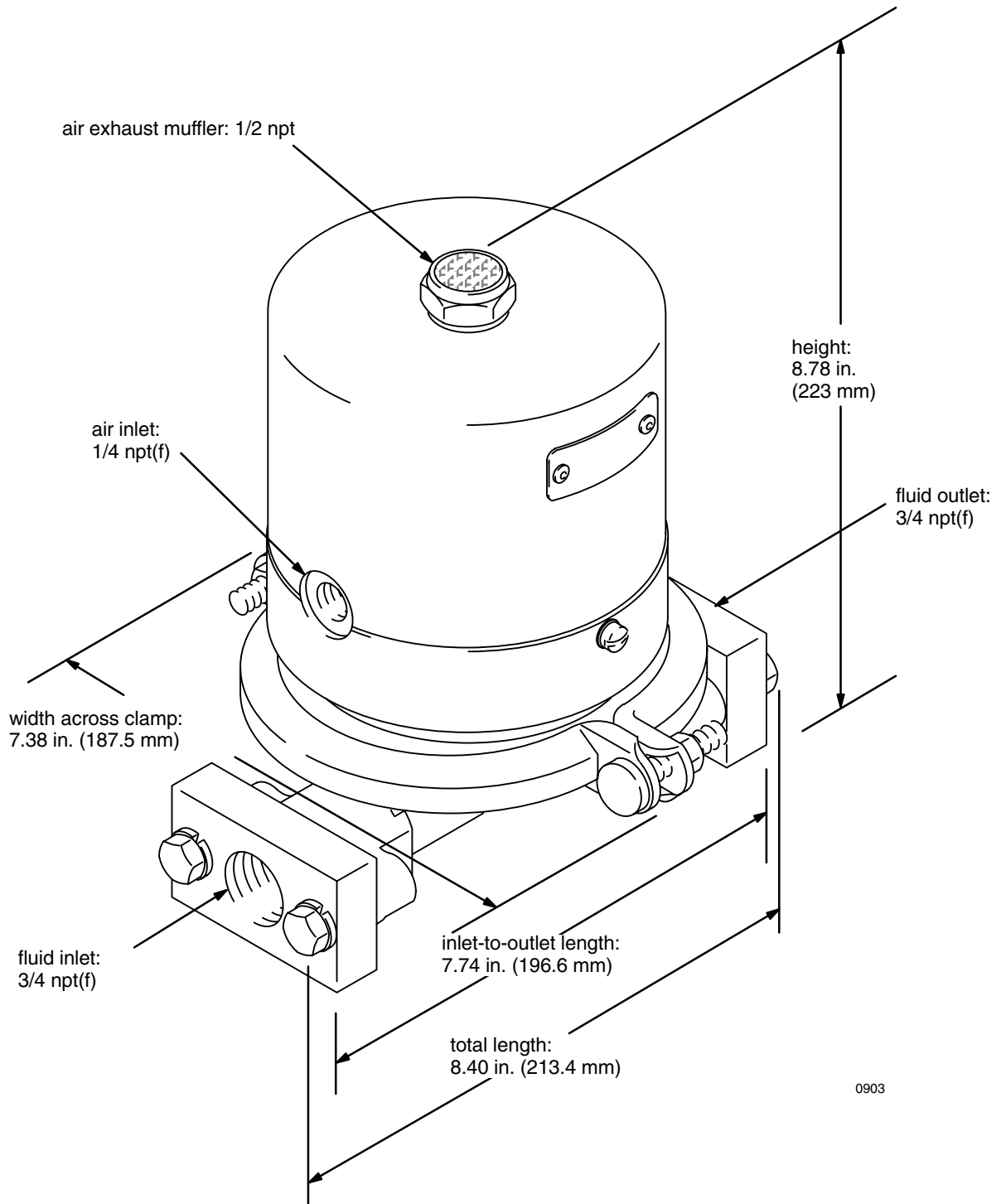

Technical Data

| | |
|--------------------------------------|--|
| Maximum fluid working pressure | 100 psi (0.7 MPa, 7 bar) |
| Air pressure operating range | 25 to 100 psi (0.18 to 0.7 MPa, 1.75 to 7 bar) |
| Maximum free flow delivery | 16 gpm (60 l/min) |
| Air inlet | 1/4 npt(f) |
| Air exhaust | 1/2 npt(f) |
| Fluid inlet | 3/4 npt(f) |
| Fluid outlet | 3/4 npt(f) |
| Wetted parts | <i>Model 224892:</i> acetal, aluminum, PTFE, 316 stainless steel <i>Model 224893:</i> acetal, aluminum, PTFE, buna-N, 316 stainless steel <i>Model 224894:</i> 316 stainless steel, PTFE <i>Model 224895:</i> 316 stainless steel, buna-N, PTFE |
| Non-wetted Parts | <i>Models 224892 and 224894:</i> acetal, aluminum, buna-N, polyurethane, bronze, plated steel, polyester (labels) <i>Models 224893 and 224895:</i> acetal, aluminum, buna-N, bronze, plated steel, polyester (labels) |
| Weight | <i>Models 224892 and 224893:</i> 10 lb (4.6 kg) <i>Models 224894 and 224895:</i> 14 lb (6.4 kg) |

Graco Standard Warranty

Graco warrants all equipment manufactured by Graco and bearing its name to be free from defects in material and workmanship on the date of sale to the original purchaser for use. With the exception of any special, extended, or limited warranty published by Graco, Graco will, for a period of twelve months from the date of sale, repair or replace any part of the equipment determined by Graco to be defective. This warranty applies only when the equipment is installed, operated and maintained in accordance with Graco's written recommendations.

This warranty does not cover, and Graco shall not be liable for general wear and tear, or any malfunction, damage or wear caused by faulty installation, misapplication, abrasion, corrosion, inadequate or improper maintenance, negligence, accident, tampering, or substitution of non-Graco component parts. Nor shall Graco be liable for malfunction, damage or wear caused by the incompatibility of Graco equipment with structures, accessories, equipment or materials not supplied by Graco, or the improper design, manufacture, installation, operation or maintenance of structures, accessories, equipment or materials not supplied by Graco.

This warranty is conditioned upon the prepaid return of the equipment claimed to be defective to an authorized Graco distributor for verification of the claimed defect. If the claimed defect is verified, Graco will repair or replace free of charge any defective parts. The equipment will be returned to the original purchaser transportation prepaid. If inspection of the equipment does not disclose any defect in material or workmanship, repairs will be made at a reasonable charge, which charges may include the costs of parts, labor, and transportation.

THIS WARRANTY IS EXCLUSIVE, AND IS IN LIEU OF ANY OTHER WARRANTIES, EXPRESS OR IMPLIED, INCLUDING BUT NOT LIMITED TO WARRANTY OF MERCHANTABILITY OR WARRANTY OF FITNESS FOR A PARTICULAR PURPOSE.

Graco's sole obligation and buyer's sole remedy for any breach of warranty shall be as set forth above. The buyer agrees that no other remedy (including, but not limited to, incidental or consequential damages for lost profits, lost sales, injury to person or property, or any other incidental or consequential loss) shall be available. Any action for breach of warranty must be brought within two (2) years of the date of sale.

Graco makes no warranty, and disclaims all implied warranties of merchantability and fitness for a particular purpose in connection with accessories, equipment, materials or components sold but not manufactured by Graco. These items sold, but not manufactured by Graco (such as electric motors, switches, hose, etc.), are subject to the warranty, if any, of their manufacturer. Graco will provide purchaser with reasonable assistance in making any claim for breach of these warranties.

In no event will Graco be liable for indirect, incidental, special or consequential damages resulting from Graco supplying equipment hereunder, or the furnishing, performance, or use of any products or other goods sold hereto, whether due to a breach of contract, breach of warranty, the negligence of Graco, or otherwise.

FOR GRACO CANADA CUSTOMERS

The parties acknowledge that they have required that the present document, as well as all documents, notices and legal proceedings entered into, given or instituted pursuant hereto or relating directly or indirectly hereto, be drawn up in English. Les parties reconnaissent avoir convenu que la rédaction du présente document sera en Anglais, ainsi que tous documents, avis et procédures judiciaires exécutés, donnés ou intentés à la suite de ou en rapport, directement ou indirectement, avec les procédures concernées.

Graco Information

For the latest information about Graco products, visit www.graco.com.

TO PLACE AN ORDER, contact your Graco distributor or call to identify the distributor closest to you:

Phone: 612-623-6921 or **Toll Free:** 1-800-328-0211 **Fax:** 612-378-3505

All written and visual data contained in this document reflects the latest product information available at the time of publication.

Graco reserves the right to make changes at any time without notice.

Original Instructions. This manual contains English. MM 308178

Graco Headquarters: Minneapolis

International Offices: Belgium, China, Japan, Korea

GRACO INC. P.O. BOX 1441 MINNEAPOLIS, MN 55440-1441

Copyright 1991, Graco Inc. is registered to ISO 9001

www.graco.com

Revised 12/2010