

From the paint room to the gun...

**Eliminating dirt in paint
with smooth-bore,
cavity-free, silicone-free,
low shear components,
fittings and systems.**



AEROSPACE



HWY/HEAVY EQUIPMENT



FURNITURE



AUTOMOTIVE

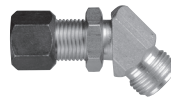

Specialty Fittings pg 6



Spray Gun Accessories pg 9



Encapsulated Ball Valves pg 13



Paint and Air Hoses pg 20



Paint System Accessories pg 27

Every high-production 'Class A' paint operation has a common enemy...
DIRT IN PAINT.

High-production 'Class A' paint shops the world over are investing in the finest filtration equipment for fluid and air paint transfer efficiency, the best in pumps, robotic spray applicators and spray guns, as well as the investment made in expert people. Yet many paint shop managers still spend several hours a day battling with dirt in paint. So what is it? Where does it come from? And why is it there?

In most cases, some of these problems initiated when the paint circulation system was first installed. Someone would purchase the lowest-cost fittings for the paint station drops... ball valves, connectors, flow control, fittings, adapters, swivels and hose. Because these fittings are not smooth-bore, cavity-free, silicone-free fittings, dried paint can easily find places to hide and eventually break free during painting operations. The result is dirt in paint, which causes paint defects and many trips to the paint repair booth. Were the low-cost fittings a good buy? Let's find out.

A hypothetical but realistic situation.
Do the math.

Automotive, furniture or cabinet plants can invest up to \$200 million in a 'Class A', high-production paint shop. Using Hosco components for the paint drops will probably cost about \$200,000, about 1/1000 of the total project's cost. If a buyer finds standard components to work in the system, the cost could be 40% to 50% less, saving about \$80,000 to \$100,000. On face value, that appears to be a wise decision. However, the hidden problem is that these low-cost components are not smooth-bore, cavity-free so they will not always completely flush out during color changes or system shut downs. The result? Dirt in the paint.

This size of operation will have paint repair booths to correct paint defects such as those caused by dirty paint. On average, a paint line that has these problems will experience up to a 10% or higher reject rate with a per part repair cost of about \$160. This means that the average shop producing 60 jobs per hour will send about 6 to a repair booth. This equates to \$960 per hour in paint repairs or \$7,680 per 8-hour shift and \$107,520 after just 14 shifts. If the plant is running two shifts per day, times 250 working days per year, then that can add up to \$3,840,000 in paint repairs per year. And the original component buyer saved \$100,000 by not buying Hosco? Do the math.

$$\begin{array}{r} 6 \times \$960/\text{HR} \\ \times 8 \\ \hline \$7680 \\ \times 14 \text{ SHIFTS} \\ \hline \$107,520 \times 2 \text{ SHIFTS,} \\ 250 \text{ DAYS/YEAR} = \\ \$3,840,000 \\ - \$100,000 \text{ HOSCO} \\ \text{INVESTMENT} \\ \hline \$3,740,000 \text{ SAVINGS!} \end{array}$$

The piping network that delivers paint consists of the pump room, the main pipe headers (1/2" and larger) and the paint station drops to the applicators (1/2" and smaller). The need to focus on eliminating dirt pockets, dead rooms plus pipe, tube and fitting assembly shelves is essential to eliminate dirt in paint. The primary culprits, as previously stated, are low-cost fittings in the paint station drops of the piping network. These low-cost fittings have places where paint can hide during flushing then dry and flake off during the next painting cycle.

Pump rooms are being improved every year with enhanced pump controls to precisely increase or decrease system volumes and pressures to help maintain optimum paint system performance. The main headers have been vastly improved with the implementation of stepless compression fittings, sanitary clamps and derivatives. In addition, improved interior microfinishes provide smooth wall designs for cleaner operation.

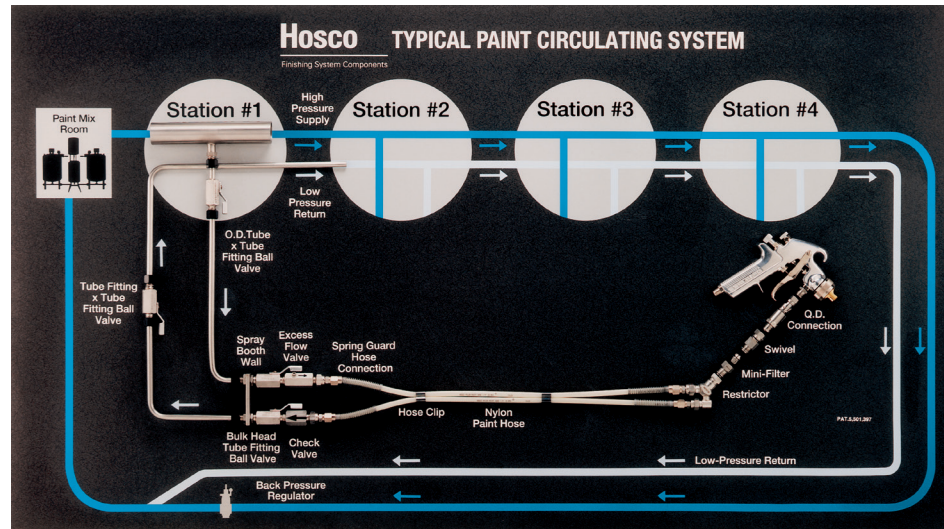

Typical manual and automatic paint station drop designs are shown and analyzed below.

Manual Stations

Number of colors	Number of stations
6 primary systems	2 prime stations
12 basecoat systems	6 basecoat stations
4 clearcoat systems	6 clearcoat stations
22 total colors	14 total manual stations

Pipe drops

12 prime station drops
72 basecoat station drops
24 clearcoat station drops
108 total station drops x 16 connection points equal 1,728 connections on manual station drops

Automatic Stations

6 prime robots/machines
16 basecoat color robots/machines (2 booths)
16 clearcoat robots/ machines (2 booths)
38 total automatic stations
36 prime station drops
224 robotic color station drops
64 clearcoat station drops
324 total station drops x 10 connection points equal 3,240 connections on robotic station drops

These illustrate the thousands of places in a typical paint delivery system where paint can hide and dry if the system was not installed using Hosco smooth bore, cavity free, silicone free fittings. Hosco paint delivery system components are available in both inch and true metric sizes.

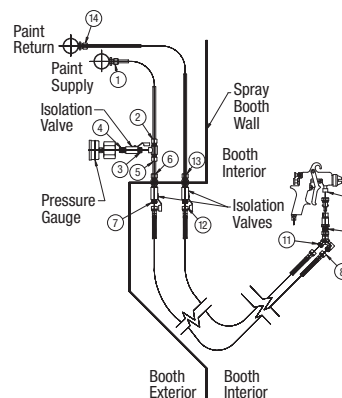

Typical Manual Spray Station

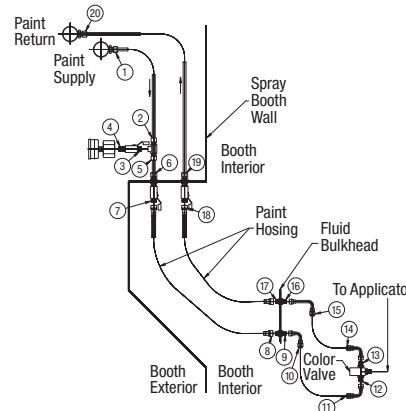

Typical Automated Spray Station

What causes the problem of dirt in paint?

80% of all paint system connections are at the paint station drops.

Paint station drops, whether for automated or manual systems, are the main source where dirt pockets can be found when using standard fittings, which include ball valves, restrictors, adaptors, fittings, swivels, couplings and extensions.

Considering that 80% of all paint circulation system joints are found on the small diameter paint station drops, it is imperative that the designers, installers and maintenance personnel give complete attention to detail to all their areas of responsibility. Using Hosco smooth bore, cavity free, silicone free components will result in increasing first run capabilities, maximizing throughput and minimizing or eliminating "dirt in paint" on production parts.

**Conventional Ball Valve
(cut-a-way)**

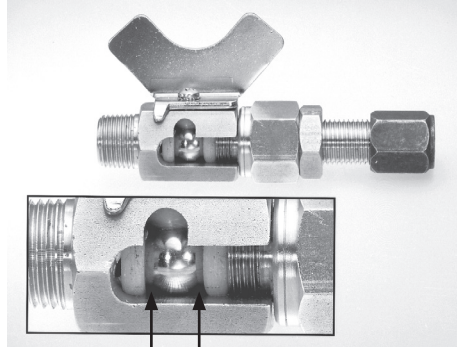

Dirt Traps

**Encapsulated Ball "Ball Valve"
(cut-a-way)**

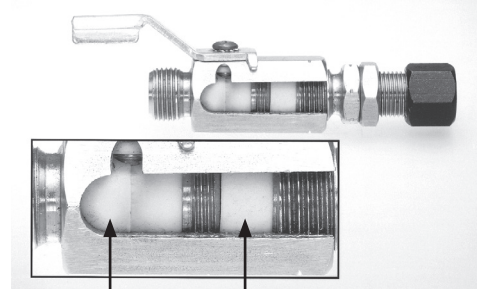

No Dirt Traps

Product Attributes

Smooth-bore

Cavity-free

Stainless steel

Microfinish surfaces

Certified
silicone-free

Performance Attributes

Minimizes turbulence and pressure loss

Minimizes "dirt in paint" generation points, eliminates dirt pockets or interior shelves

Strongest material of construction

Special processes to weld, clean and prepare Hosco products for intended uses

Hosco products are manufactured in silicone-free environment to automotive style paint standards

Benefits

Lower operating pressures and degradation of paint

Less repairs, lower facility costs, faster color pulls, less solvent/time to flush & clean

Highest level of safety, compatible with all paints and finishes

Quick to flush, easy to clean

Shipped clean and ready for installation, no further processing required

Hosco products are available in NPS, NPT, BSPP, BSPT and PT for worldwide application and availability and supported by a worldwide network of distributors and expert installers.

**Hosco
smooth- bore,
cavity-free
products
pave the way
for dirt-free
paint systems.**



Encapsulated Ball Valves

All Hosco 316 series patented encapsulated ball valves have no cavities around the ball so there is no place for paint to collect and dry. They also include PTFE seats and an adjustable retainer ring. All ball valves are rated for 500 PSI (35 BAR) working pressure.

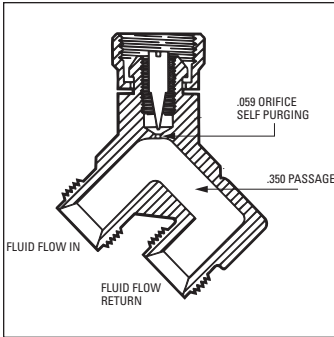

Flow Control Restrictors

Hosco flow control restrictors are available in stainless steel or lightweight composite materials. They are compact, low cost, lightweight, tamper proof, replace gun regulators, and have a smooth flow .350 I. D. recirculating passage with no pressure loss.



“Low Shear” Cavity Free Connection Fittings

All Hosco connection fittings feature its new “Low Shear” design that incorporates a taper-to-taper connection, which eliminates the blunt end or shelf surface found in conventional fittings. The design enhances Hosco’s smooth bore, cavity free product line helping metallic paint finishes retain their color, luster and quality while reducing system pressure loss, speeding installation procedures and furthering overall safety.



Quick Disconnect “No-spit” Fittings

Hosco paint quick disconnects work precisely with Hosco stems to eliminate the accumulation of paint and sludge that forms during everyday use of paint quick disconnects sets. The fittings eliminate the need for frequent solvent flushing or washing, cleaning away accumulated waste to prevent paint pits.

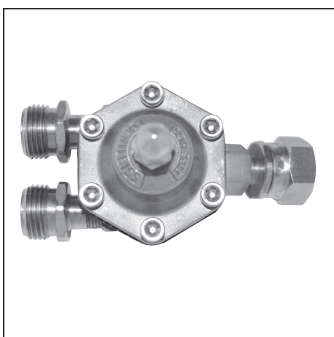

Restrictor/Regulator

The Hosco HHR-6 restrictor/regulator incorporates a restrictor on a regulated paint outlet and then permits adjusting it to the desired flow rate to the spray gun. This helps attain maximum accuracy and repeatability while maintaining spray gun control even in the extremely low range. This restrictor/regulator is well suited for painting large structures with their inherent elevation changes from top to bottom such as aircraft, trucks and buses or for electrostatic air spray/HVLP painting applications.

Angle Fittings



PART NO.	DESCRIPTION
2T - 6 - 45	1/8" NPT(M) x 3/8" NPS(M) - 45°
6 - 6 - 45	3/8" NPS(M) x 3/8" NPS(M) - 45°
6T - 4 - 45	3/8" NPT(M) x 1/4" NPS(M) - 45°
6T - 6 - 45	3/8" NPT(M) x 3/8" NPS(M) - 45°

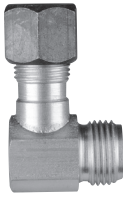

PART NO.	DESCRIPTION
6 - 6TF - 90	3/8" NPS(M) x 3/8" TF - 90°
6 - 8TF - 90	3/8" NPS(M) x 1/2" TF - 90°



PART NO.	DESCRIPTION
6SN - 6 - 45	3/8" NPS(M) x 3/8" NPS(F) - 45°



PART NO.	DESCRIPTION
2T - 4 - 90	1/8" NPT(M) x 1/4" NPS(M) - 90°
2T - 4B - 90	1/8" NPT(M) x 1/4" BSP(M) - 90°
2T - 6 - 90	1/8" NPT(M) x 3/8" NPS(M) - 90°
4T - 4 - 90	1/4" NPT(M) x 1/4" NPS(M) - 90°
4T - 4B - 90	1/4" NPT(M) x 1/4" BSP(M) - 90°
4T - 6 - 90	1/4" NPT(M) x 3/8" NPS(M) - 90°



PART NO.	DESCRIPTION
6SN - 6BTF - 45 - 316	3/8" NPS(F) x 3/8" BTF - 45°

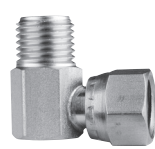

PART NO.	DESCRIPTION
4SN - 4 - 90	1/4" NPS(F) x 1/4" NPS(M) - 90°
4SN - 6 - 90	1/4" NPS(F) x 3/8" NPS(M) - 90°
6SN - 4T - 90	3/8" NPS(F) x 1/4" NPT(M) - 90°
6SN - 6 - 90	3/8" NPS(F) x 3/8" NPS(M) - 90°
6SN - 6T - 90	3/8" NPS(F) x 3/8" NPT(M) - 90°



PART NO.	DESCRIPTION
6 - 6BTF - 45	3/8" NPS(M) x 3/8" BTF(M) - 45°

Couplings and Caps



PART NO.	DESCRIPTION
4SN - 4T(F)	1/4" NPS(F) x 1/4" NPT(F)
6SN - 6T(F)	3/8" NPS(F) x 3/8" NPT(F)
6SN - 4T(F)	3/8" NPS(F) x 1/4" NPT(F)



PART NO.	DESCRIPTION
4SN - 4SN	1/4" NPS(F) x 1/4" NPS(F)
4SN - 6SN	1/4" NPS(F) x 3/8" NPS(F)
6SN - 6SN	3/8" NPS(F) x 3/8" NPS(F)
4SNB - 4SNB	1/4" BSP(F) x 1/4" BSP(F)
4SNB - 6SNB	1/4" BSP(F) x 3/8" BSP(F)
6SNB - 6SNB	3/8" BSP(F) x 3/8" BSP(F)

Couplings and Caps (Cont.)



PART NO.	DESCRIPTION
4 - CAP	1/4" NPS(F) x CAP
6 - CAP	3/8" NPS(F) x CAP
4B - CAP	1/4" BSP(F) x CAP
6B - CAP	3/8" BSP(F) x CAP



PART NO.	DESCRIPTION
14 - HB	1/4" NPS(M) x CAP
38 - HB	3/8" NPS(M) x CAP

Adaptors



PART NO.	DESCRIPTION
2T - 2B	1/8" NPT(M) x 1/8" BSP(M)
2T - 4	1/8" NPT(M) x 1/4" NPS(M)
2T - 4B	1/8" NPT(M) x 1/4" BSP(M)
2T - 4T	1/8" NPT(M) x 1/4" NPT(M)
2T - 6	1/8" NPT(M) x 3/8" NPS(M)
2T - 6B	1/8" NPT(M) x 3/8" BSP(M)
4 - 2BSP	1/4" NPS(M) x 1/8" BSP(M)
4 - 6	1/4" NPS(M) x 3/8" NPS(M)
4B - 6	1/4" BSP(M) x 3/8" BSP(M)
4T - 4	1/4" NPT(M) x 1/4" NPS(M)
4T - 4B	1/4" NPT(M) x 1/4" BSP(M)
4T - 6	1/4" NPT(M) x 3/8" NPS(M)
6 - 6	3/8" NPS(M) x 3/8" NPS(M)
6B - 6B	3/8" BSP(M) x 3/8" BSP(M)
6T - 4	3/8" NPT(M) x 1/4" NPS(M)
6T - 4B	3/8" NPT(M) x 1/4" BSP(M)
6T - 4T	3/8" NPT(M) x 1/4" NPT(M)
6T - 6	3/8" NPT(M) x 3/8" NPS(M)
6T - 6B	3/8" NPT(M) x 3/8" BSP(M)
6T - 6T	3/8" NPT(M) x 3/8" NPT(M)
8T - 6	1/2" NPT(M) x 3/8" NPS(M)
8T - 6B	1/2" NPT(M) x 3/8" BSP(M)



PART NO.	DESCRIPTION
4 - 4T(F)	1/4" NPS(M) x 1/4" NPT(F)
6 - 4T(F)	3/8" NPS(M) x 1/4" NPT(F)
6 - 6T(F)	3/8" NPS(M) x 3/8" NPT(F)



PART NO.	DESCRIPTION
4 - 6TF	1/4" NPS(M) x 3/8" TF
6 - 6TF	3/8" NPS(M) x 3/8" TF
6T - 12mm TF	3/8" NPT(M) x 12mm Tube Fitting
6T - 10mm TF	3/8" NPT(M) x 10mm Tube Fitting



PART NO.	DESCRIPTION
4 - 4RB	1/4" NPS(M) x 1/4" NPS(M) Bulkhead
6 - 6RB	3/8" NPS(M) x 3/8" NPS(M) Bulkhead
6T - 6RB	3/8" NPT x 3/8" NPS(M) Bulkhead



PART NO.	DESCRIPTION
4SN - 2T	1/4" NPS(F) x 1/8" NPT(M)
4SN - 4	1/4" NPS(F) x 1/4" NPS(M)
4SN - 4T	1/4" NPS(F) x 1/4" NPT(M)
4SN - 6	1/4" NPS(F) x 3/8" NPS(M)
4SN - 6T	1/4" NPS(F) x 3/8" NPT(M)
4SNB - 4B	1/4" BSP(F) x 1/4" BSP(M)
6SN - 2T	3/8" NPS(F) x 1/8" NPT(M)
6SN - 4	3/8" NPS(F) x 1/4" NPS(M)
6SN - 4T	3/8" NPS(F) x 1/4" NPT(M)
6SN - 6T	3/8" NPS(F) x 3/8" NPT(M)
6SNB - 4B	3/8" BSP(F) x 1/4" BSP(M)
6SN - 8T	3/8" NPS(F) x 1/2" NPT(M)

Adaptors (Cont.)



PART NO.	DESCRIPTION
6SN - 6BTF	3/8" NPS(F) x 3/8" BTF
6SN - 8BTF	3/8" NPS(F) x 1/2" BTF
6SN - 10MMBTF	3/8" NPS(F) x 10mm BTF
6SN - 12MMBTF	3/8" NPS(F) x 12mm BTF



PART NO.	DESCRIPTION
6TF - 6BTF	3/8" TF x 3/8" BTF



PART NO.	DESCRIPTION
6SN - 6TF	3/8" NPS(F) x 3/8" TF
6SN - 4TF	3/8" NPS(F) x 1/4" TF
6SN - 8TF	3/8" NPS(F) x 1/2" TF
6SN - 10MMBTF	3/8" NPS(F) x 10mm TF
6SN - 12MMBTF	3/8" NPS(F) x 12mm TF



PART NO.	DESCRIPTION
6TF - 6RB	3/8" TF x 3/8" NPS(M)RB
8TF - 6RB	1/2" TF x 3/8" NPS(M)RB



PART NO.	DESCRIPTION
4SN - 4JIC	1/4" NPS(F) x 1/4" JIC/AN
4 - 4JIC	1/4" NPS(M) x 1/4" JIC/AN
4 - 6JIC	1/4" NPS(M) x 3/8" JIC/AN
6 - 4JIC	3/8" NPS(M) x 1/4" JIC/AN
6 - 6JIC	3/8" NPS(M) x 3/8" JIC/AN



PART NO.	DESCRIPTION
6 - 6TUBE	3/8" NPS(M) x 3/8" OD Tube
6T - 6TUBE	3/8" NPT(M) x 3/8" OD Tube
6 - 8TUBE	3/8" NPS(M) x 1/2" OD Tube
6T - 8TUBE	3/8" NPT(M) x 1/2" OD Tube
6 - 10MMTUBE	3/8" NPS(M) x 10mm Tube
6T - 10MMTUBE	3/8" NPT(M) x 10mm Tube
6 - 12MMTUBE	3/8" NPS(M) x 12mm Tube
6T - 12MMTUBE	3/8" NPT(M) x 12mm Tube



PART NO.	DESCRIPTION
DR1 - 2 - 4*	1/4" NPS(M)

*For inlet to Ransburg DR-1 family of fluid regulators.



PART NO.	DESCRIPTION
4 - 2BSP - AWS	1/4" NPS(M) x AW Flow Meter - Short
4 - 2BSP - AWL	1/4" NPS(M) x AW Flow Meter - Long

Note: Hole sizes for bulkhead mounting:

	Hole Size
3/8" Bulkhead Tube Fitting (6BTF)	37/64" (15mm)
1/2" Bulkhead Tube Fitting (8BTF)	49/64" (19.5mm)
3/8" NPS(M) Reverse Bulkhead Hose Thread (6RB)	11/16" (17.5mm)
10mm Bulkhead Tube Fitting	16.5mm
12mm Bulkhead Tube Fitting	18.5mm
13mm Bulkhead Tube Fitting	20.5mm

Regulator/Restrictor

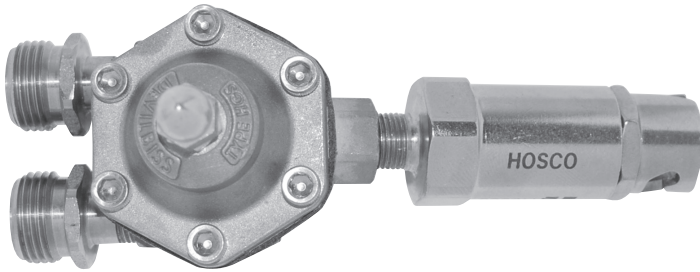
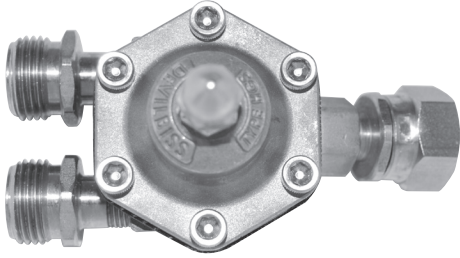

PART NO.	DESCRIPTION
HRR - 4	1/4" NPS(M) Circulating Connectors x 3/8" NPS(F)
HRR - 6	3/8" NPS(M) Circulating Connectors x 3/8" NPS(F) Gun Connection

PART NO.	DESCRIPTION
HRRQD - 4	1/4" NPS(M) Circulating Connectors x Hosco Paint Quick Disconnect with 0.059" Fixed Restrictor
HRRQD - 6	3/8" NPS(M) Circulating Connectors x Hosco Paint Quick Disconnect with 0.059" Fixed Restrictor

Recommended Applications:

- Aircraft
- Farm Implement
- Construction Equipment
- High Efficiency Air Spray or HVLP
- Spray Stations with Large Elevation Changes

Hosco patented regulator/restrictor family of products allows manual sprayers to consistently and precisely control spray gun flow rates from 100 cc/min to 1000 cc/min with little regard to head pressure or gun elevation changes. Combining the functions of a regulator (which controls pressure) and a restrictor (which controls flow rate) into this compact package allows sprayers to provide consistent film builds regardless of the change in gun position or elevation. With the implementation of high transfer efficiency spray guns, this precise control is much more important at the lower station flow rates of these spray guns.

As you can see from the graph at the right, a regulator control device alone is not recommended below 275 cc/min as it is recommended to operate the regulator between 15 psi and 30 psi outlet pressure. Combining the integral restrictor creates outlet flow restriction to control the flow to 100 cc/min lower thresholds. Hosco recommends fluid inlet pressure of 80 psig or more from the paint circulation system.

BONNET PRESSURE VS FLOW RATE
HGS STANDARD AND LOW FLOW COMPARISON

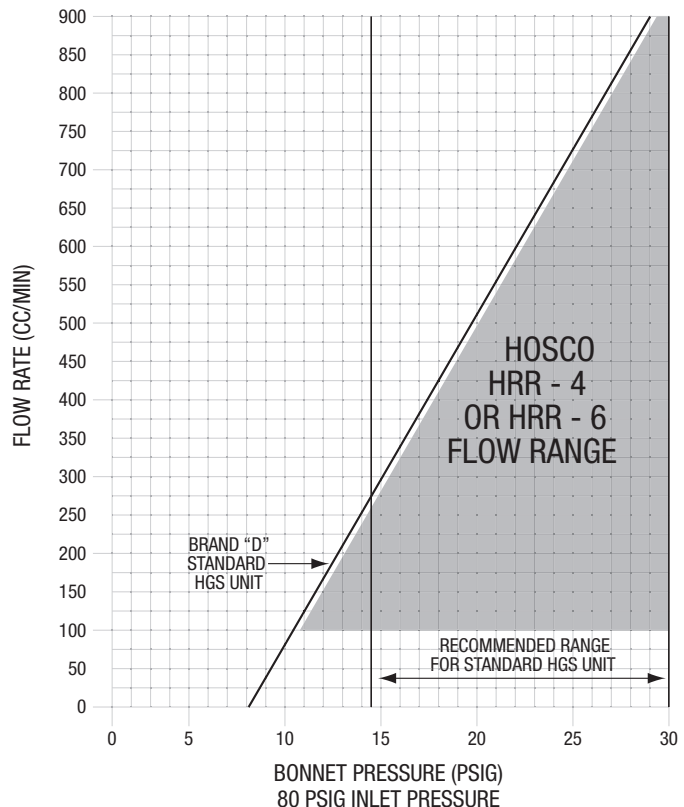

All Hosco products are smooth-bore, cavity-free and microfinished to pave the way for dirt-free paint.

Spray Gun Accessories

QD Connections and Stems

**CSD - 6
Dummy Stem**



SSQD - 6 - 316



- Patented no-spit design
- Lightweight
- Ergonomically designed
- Eliminates contamination

**GFQD - 6
Glass-filled Nylon**



**SS-STEM - 4 - 316
SS-STEM - 6 - 316
SS-STEM - 6CV - 316**



PART NO.	DESCRIPTION	316 SST	LIGHTWEIGHT COMPOSITE	303 SST
SSQD - 6 - 316	3/8" NPS(M) QD	•		
SSQD - 6B - 316	3/8" BSP(M) QD	•		
SSQD - 2T - 316	1/8" NPT(M) QD	•		
SSQD - 4 - 316	1/4" NPS(M) QD	•		
SSQD - 4B - 316	1/4" BSP(M) QD	•		
SSQD - 4T - 316	1/4" NPT(M)	•		
SSQD - 6T - 316	3/8" NPT(M)	•		
GFQD - 6	3/8" NPS(M) QD		•	
GFQD - 6B	3/8" BSP(M) QD		•	
QDRK - 6	Repair Kit includes spring, ball and seals			
SS - STEM - 4 - 316	1/4" NPS(F) QD Stem	•		
SS - STEM - 4B - 316	1/4" BSP(F) QD Stem	•		
SS - STEM - 6 - 316	3/8" NPS(F) QD Stem	•		
SS - STEM - 6B - 316	3/8" BSP(F) QD Stem	•		
SS - STEM - 6CV - 316	3/8" NPS(F) QD Stem with Ball Check	•		
CSD - 6	3/8" NPSM(F) Dummy Stem			•
CSD - 6B	3/8" BSP(F) Dummy Stem			•

Restrictors

Stainless Steel Restrictor

- Stainless steel or composite
- Lightweight
- Compact
- Replaces gun regulator
- Low cost
- .350 I.D. recirculating passage
- No pressure loss
- Tamper proof

PART NO.	DESCRIPTION	SST	LIGHTWEIGHT COMPOSITE	PART NO. FOR BSP THREAD
RIL - 6	3/8" NPS(F) x 3/8" NPS(M)	•		RIL - 6B
RIL - 6 - AJ	3/8" NPS(M) x 3/8" NPS(F)	•		RIL - 6B - AJ
RY - 4	3/8" NPS(F) x 1/4" NPS(M)	•		RY - 4B
RY - 6	3/8" NPS(F) x 3/8" NPS(M)	•		RY - 6B
RY - 4 - AJ	3/8" NPS(F) x 1/4" NPS(M)	•		RY - 4B - AJ
RY - 6 - AJ	3/8" NPS(F) x 3/8" NPS(M)	•		RY - 6B - AJ
RY - 4L	3/8" NPS(F) x 1/4" NPS(M)		•	RY - 4LB
RY - 6L	3/8" NPS(F) x 3/8" NPS(M)		•	RY - 6LB

Hosco Tamper Proof Restrictors

RY - 6



RY - 6L



RIL - 6



Hosco Externally Adjustable Restrictors

RY - 6 - AJ



RIL - 6 - AJ



877.852.7782



hosco.net

Restrictor Adjusting Block

- To adjust restrictor flow at gun
- Hardened tip (resists breakage)
- Large adjusting knob
- Compact
- Gauge Port 1/4" NPT(F)

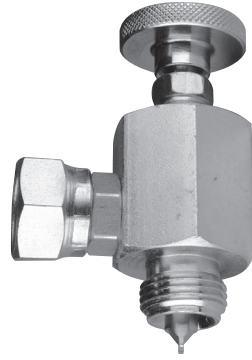

PART NO.	DESCRIPTION
RAB - 6	3/8" NPS(F) x 3/8" NPS(M)
RAB - 6B	3/8" BSP(F) x 3/8" BSP(M)

Circulation Adapters



RY - 6 - 312

PART NO.	DESCRIPTION	SST	PART NO. FOR BSP THREAD
RY - 4 - 312	3/8" NPS(F) x 1/4" NPS(M)	•	RY - 4B - 312
RY - 6 - 312	3/8" NPS(F) x 3/8" NPS(M)	•	RY - 6B - 312
RY - 6 - 187 - ST	3/8" NPS(F) x 3/8" NPS(M)	•	
RY - 8 TF - 6TF	1/2" TF x 3/8" TF x 3/8" TF	•	
RY - 6Y - 312	3/8" NPS(F) x 3/8" NPS(M) x 3/8" NPS(M)	•	
6SN - 6 - 6 - 6	3/8" NPS(F) x 3/8" NPS(M) x 3/8" NPS(M) x 3/8" NPS(M)	•	



RY-6-187-ST



RY-8TF-6TF



RY-6Y-312



6SN-6-6-6

Mini-Filter

Stainless Steel Final Filter for All Spray Guns

- Easy installation
- Eliminates prefilter
- Small internal volume (reducing purge time and paint loss)
- Lightweight
- 40, 70, 100, 150, 200, 325, or 500 mesh high capacity filter cartridge, replaceable
- Low cost

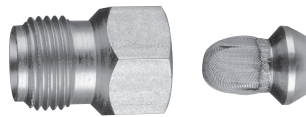

PART NO.	SIZE	PART NO. FOR BSP	FILTER CARTRIDGE ONLY
MF - 6 - 40	40 mesh / 350 micron	MF - 6B - 40B	MFC - 40
MF - 6 - 70	70 mesh / 200 micron	MF - 6B - 70B	MFC - 70
MF - 6 - 100	100 mesh / 149 micron	MF - 6B - 100B	MFC - 100
MF - 6 - 150	150 mesh / 100 micron	MF - 6B - 150B	MFC - 150
MF - 6 - 200	200 mesh / 74 micron	MF - 6B - 200B	MFC - 200
MF - 6 - 325	325 mesh / 44 micron	MF - 6B - 325B	MFC - 325
MF - 6 - 500	500 mesh / 25 micron	MF - 6B - 500B	MFC - 500
MFB	Body 3/8" NPS M x F	MFB - B	3/8" BSP M x F

Swivels

- Stainless steel live swivel
- Gives flexibility and ease to the spray painter
- Reduces fatigue on manual operations
- Lightweight
- Compact

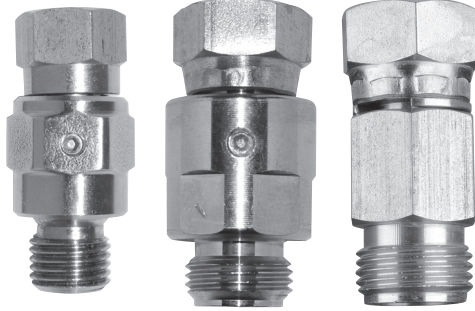

PART NO.	DESCRIPTION
4SN - 4SW	1/4" NPS(F) x 1/4" NPS(M)
6SN - 6SW	3/8" NPS(F) x 3/8" NPS(M)
S - 6M	3/8" NPS(F) x 3/8" NPS(M)
S - 6MB	3/8" BSP(F) x 3/8" BSP(M)

Pressure Gages and Tees

- 1/4" NPT(M) 316 SST
- Top mount (other configurations available)
- 0-300 PSI (0-21 BAR)
- 2-1/2" gage face dia.
- Glycerine filled



PART NO.	DESCRIPTION
PG - 300 - 4T	1/4" NPT(M) CONNECTION
PG - 300 - 4T(F)	1/4" NPT(F) CONNECTION
PG - 300 - 6	3/8" NPS(M) CONNECTION



PART NO.	DESCRIPTION
6SN - 6 - 4T(F) - 316	3/8" NPS(F) x 3/8" NPS(M) x 1/4" NPT(F)



PART NO.	DESCRIPTION
6SN - 6TF - 4T(F) - 316	3/8" NPS(M) x 3/8" OD TF x 1/4" NPT(F)
6SN - 6BTF - 6SN - 316	3/8" NPS(F) x 3/8" OD Bulkhead TFS x 3/8" NPS(F)

Hosco Paint Station Ball Valves

SSBV Series - Standard of the Industry

Eliminating the nagging "dirt in paint" problems starts with having the paint drops comprised of Hosco smooth-bore, cavity-free, microfinished components. Hosco SSBV paint station ball valves are all 316 stainless steel, smooth-bore, fully encapsulated and cavity-free allowing them to flush easily and quickly so there is no place for dried paint to hide. The SSBV family is available in every configuration needed in paint circulation drop stations from 1/4" to 5/8" or 8mm to 14mm sizes- threaded, bulkhead threaded, compression, bulkhead compression, and tube up to 18" long. The full featured SSBV family includes adjustable packing for cradle to grave service in a paint shop's 25 year life, with PTFE packing and seats that provide chemical resistance to all of the coatings used or anticipated for use in the future.

- Fully encapsulated: Flush quickly and easily during color changes or system cleaning
- Cavity free: Eliminates dirt pockets, dead rooms, thread pockets and shelves that can create sources of "dirt in paint"
- One piece body design: No body seams or leak points like multiple piece body designs of standard industrial WOG designs... made for hazardous/flammable fluids like paint and solvents
- Adjustable packing provides longest life and leak free operation of station ball valves
- Virtually every configuration available for paint circulation designs around the world. NPS, BSP(PF), NPT, BPST(PT), tube stubs, compression, bulkhead compression or reverse bulkhead threaded ends in all fractional inch and metric sizes encountered in paint station drops

HBV Compact Stainless Steel Ball Valves



The new Hosco HBV Series Mini Ball Valves can lessen your engineering problems for compact installations such as robot arms, enclosures and bulkhead plates. They're 1/2" shorter than typical SSBV ball valves plus they have a new butterfly handle that results in a smaller footprint.

- Full port ball: Same 7mm ball performance as our current smooth bore SSBV series
- PTFE encapsulated seal: Chemical, pressure, temperature stability and cavity free
- All stainless steel construction: Standard in 303 and 316 is available on request
- Available in three different bodies: Compression (optional bulk head), tube stub, and male threaded choices (metric & fractional inch, BSP, PF, NPS, BSPT, PT and NPT)
- Available in six different end connections: Compression (optional bulkhead), tube stub, and male & female threaded choices including reverse bulkhead

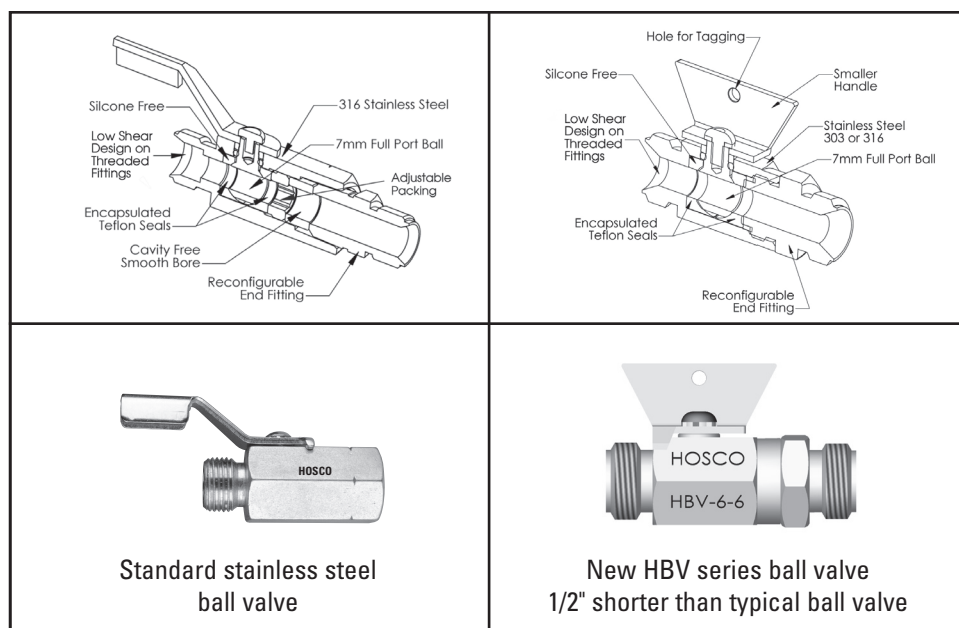
For standard configurations and special orders see reverse side.

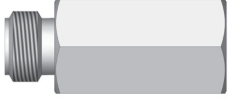

SSBV
The paint
circulation
system
standard.



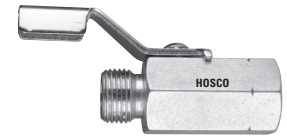



Body End Connectors		
Male Thread 	1/4"	3/8"
	-4 (NPS)	-6 (NPS)
	-4T (NPT)	-6T (NPT)
	-4B (BSP)	-6B (BSP)
	-4BT (BSPT)	-6BT (BSPT)
Tube Stub 17" Max  1.5"/38mm STD	METRIC	FRACTIONAL
	-10MMTUBE	-6TUBE (3/8)
	-12MMTUBE	-8TUBE (1/2)
Compression 	METRIC	FRACTIONAL
	-10MMTF	-6TF (3/8)
	-12MMTF	-8TF (1/2)

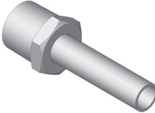

Sample of ordering:
SSBV - X - X - 316
(Body (Fitting end) end)

SSBV-6-6-316
3/8" NPS(M) x
3/8" NPS(M)
303 SST versions
available upon
request

For non-standard
configurations call:
248.912.1750 for a
quote or Email:
info@hosco.net

Fitting end connectors		
Male Thread 	1/4"	3/8"
	-4 (NPS)	-6 (NPS)
	-4T (NPT)	-6T (NPT)
	-4B (BSP)	-6B (BSP)
	-4BT (BSPT)	-6BT (BSPT)
Female Thread 	1/4"	3/8"
	-4SN (NPS)	-6SN (NPS)
	-4T(F) (NPT)	-6T(F) (NPT)
	-4SNB (BSP)	-6SNB (BSP)
	-4BT(F) (BSPT)	-6BT(F) (BSPT)
Tube Stub 17" Max  1.5"/38mm STD	METRIC	FRACTIONAL
	-10MMTUBE	-6TUBE (3/8)
	-12MMTUBE	-8TUBE (1/2)
Compression 	METRIC	FRACTIONAL
	-10MMTF	-6TF (3/8)
	-12MMTF	-8TF (1/2)
Bulk Head Compression 	METRIC	FRACTIONAL
	-10MMBTF	-6BTF (3/8)
	-12MMBTF	-8BTF (1/2)
Reverse Bulkhead 	METRIC	FRACTIONAL
		6RB (NPS)

HBV New compact, full-feature valves.

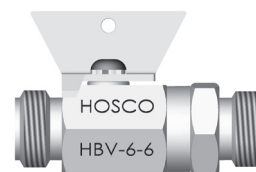





Sample of ordering:

HBV - X - X
(Body (Fitting
end) end)

HBV-6-6
3/8" NPS(M) x
3/8" NPS(M)
316 SST versions
available upon
request

For non-standard
configurations call:
248.912.1750 for a
quote or Email:
info@hosco.net

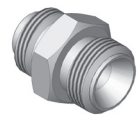
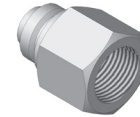
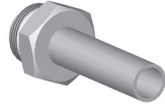
Body end connectors		
Male Thread 	1/4"	3/8"
	-4 (NPS)	-6 (NPS)
	-4T (NPT)	-6T (NPT)
	-4B (BSP),PF	-6B (BSP),PF
	-4BT (BSPT),PF	-6BT (BSPT),PF
Tube Stub 17" Max  1.5"/38mm STD	METRIC	FRACTIONAL
	-10MMTUBE	-6TUBE (3/8)
	-12MMTUBE	-8TUBE (1/2)
	-14MMTUBE	-10TUBE (5/8)
Compression 	METRIC	FRACTIONAL
	-8MMTF	-4TF (1/4)
	-10MMTF	-6TF (3/8)
	-12MMTF	-8TF (1/2)
	-14MMTF	-10TF (5/8)

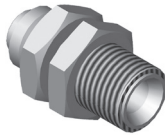
Fitting end connectors		
Male Thread 	1/4"	3/8"
	-4 (NPS)	-6 (NPS)
	SO -4T (NPT)	-6T (NPT)
	SO -4B (BSP),PF	-6B (BSP),PF
	SO -4BT (BSPT),PT	-6BT (BSPT),PT
Female Thread 	1/4"	3/8"
	SO -4SN (NPS)	-6SN (NPS)
	-4T(F) (NPT)	-6T(F) (NPT)
	SO -4SNB (BSP),PF	-6SNB (BSP),PF
	-4BT(F) (BSPT),PT	-6BT(F) (BSPT),PT
Tube Stub 17" Max  1.5"/38mm STD	METRIC	FRACTIONAL
	-10MMTUBE	-6TUBE (3/8)
	-12MMTUBE	-8TUBE (1/2)
	-14MMTUBE	-10TUBE (5/8)
Compression 	METRIC	FRACTIONAL
	SO -8MMTF	SO -4TF (1/4)
	-10MMTF	-6TF (3/8)
	-12MMTF	-8TF (1/2)
	-14MMTF	-10TF (5/8)
Bulk Head Compression 	METRIC	FRACTIONAL
	SO -8MMBTf	SO -4BTf (1/4)
	-10MMBTf	-6BTf (3/8)
	-12MMBTf	-8BTf (1/2)
	-14MMBTf	-10BTf (5/8)
Reverse Bulkhead 	METRIC	FRACTIONAL
		6RB (NPF)

SO - SPECIAL ORDER NOT IN STOCK - PRICING HIGHLY DEPENDENT ON QUANTITY

877.852.7782



hosco.net

**Hosco SSBV
Series 316
stainless steel
encapsulated
paint station
ball valves.**

Automation Paint Station Ball Valve Assemblies

New Hosco "HRS" rail system paint station drop assemblies are cavity free, smooth bore and provide quick, economical installation for robotic rail stations or fixed automation systems. The system is made with up to six stepped length ball valve designs to facilitate compact paint station construction as shown in the photo to the right.

2 Station Configuration

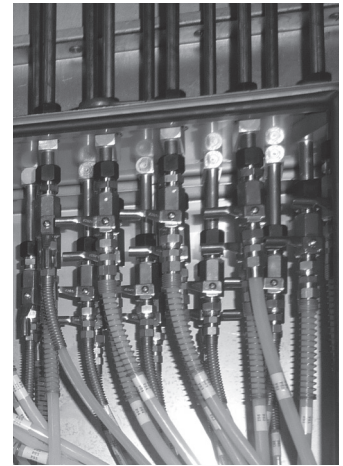

3 Station Configuration

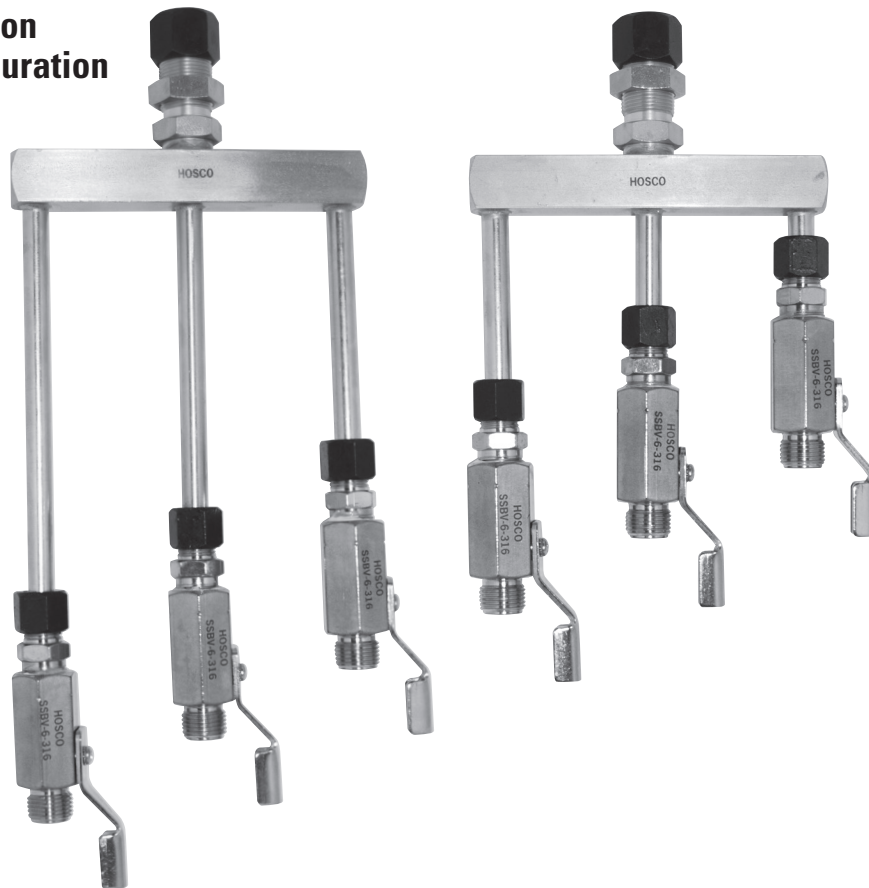

Automation Paint Station Ball Valve Assemblies

Hosco SSBV
Series 316
stainless steel
encapsulated
paint station
ball valves.

The benefits of using the new HRS paint station drop assemblies include:

- Faster installations, less downtime
- 50-67% reduction of drop tube piping over conventional paint station configurations saves over \$10,000 per spray zone
- 50% reduction of pressure loss in paint systems reduces pump and system component wear, service and calibration exponentially while making the system safer with lower pressure
- Reduction of material shear, maintaining paint color and glamor for longer periods

The schematics below compare the old installation methods with the new Hosco rail system.

Traditional Installation Method

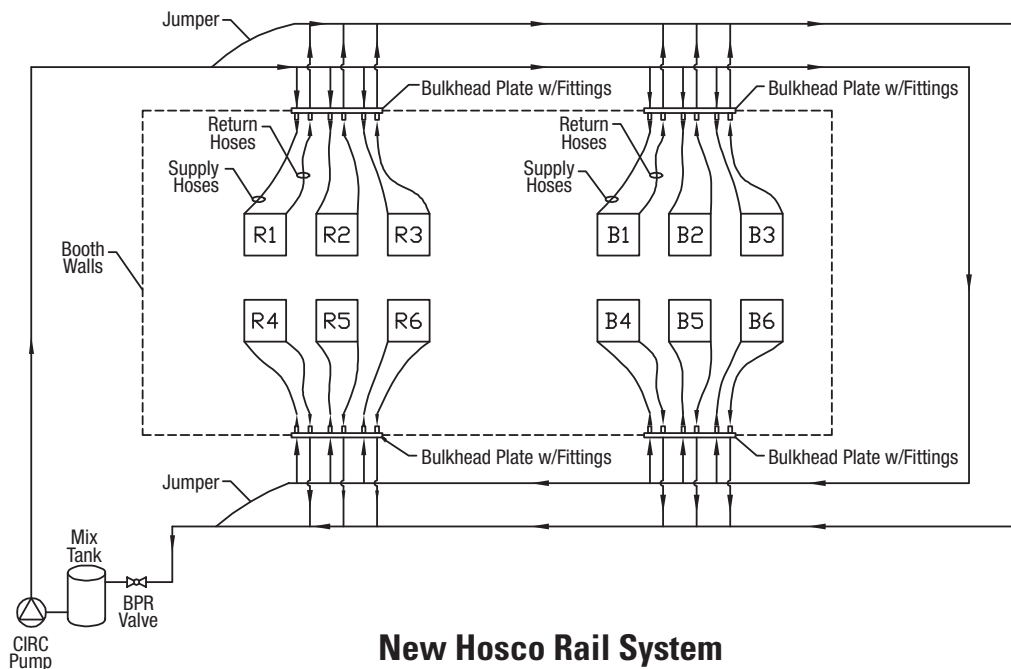

New Hosco Rail System

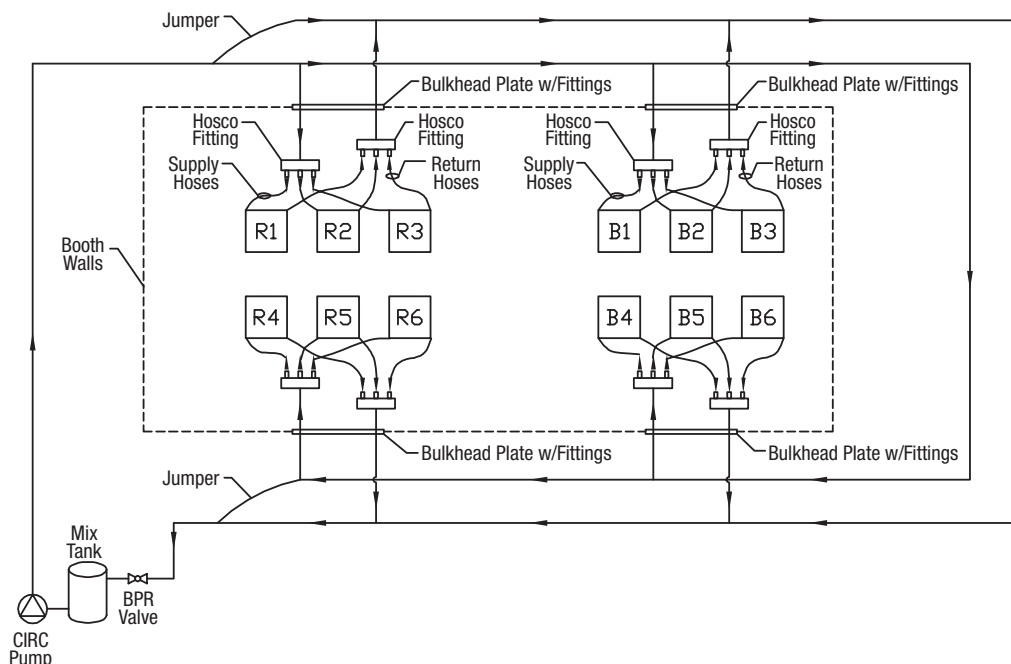

New high performance and economical family of ball valves for compact applications.

HRS Hosco Rail System

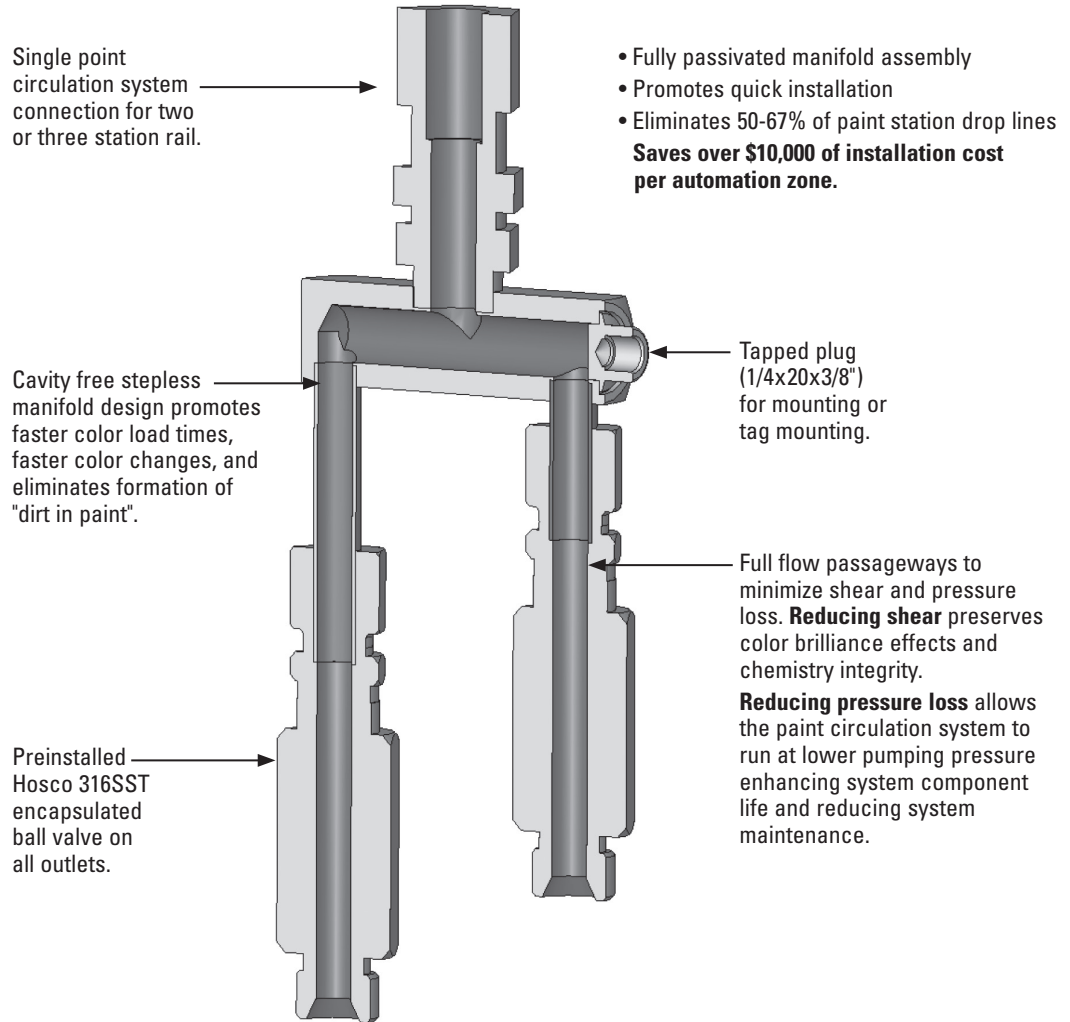

- Fully passivated manifold assembly
 - Promotes quick installation
 - Eliminates 50-67% of paint station drop lines
- Saves over \$10,000 of installation cost per automation zone.**

TWO OUTLET MANIFOLD		THREE OUTLET MANIFOLD	
HRS-200	1/2" bulkhead compression inlet x (2) 3/8" NPS(M) outlet ball valves (stepped at 1" & 2" for hose connection access in drop box)	HRS-300	5/8" bulkhead compression inlet x (3) 3/8" NPS(M) outlet ball valves (stepped at 1", 2" & 3" for hose connection access in drop box)
HRS-200L	Same as HRS200 except stepped at 3" & 4"	HRS-300L	Same as HRS300 except stepped at 4", 5" & 6"
HRS-251	12mm bulkhead compression inlet x (2) 3/8" NPS(M) outlet ball valves (stepped at 1" & 2" for hose connection access in drop box)	HRS-351	12mm bulkhead compression inlet x (3) 3/8" NPS(M) outlet ball valves (stepped at 1", 2" & 3" for hose connection access in drop box)
HRS-251L	Same as HRS251 except stepped at 3" & 4"	HRS-351L	Same as HRS351 except stepped at 4", 5" & 6"
HRS-254	18mm bulkhead compression inlet x (2) 3/8" NPS(M) outlet ball valves (stepped at 1" & 2" for hose connection access in drop box)	HRS-354	18mm bulkhead compression inlet x (3) 3/8" NPS(M) outlet ball valves (stepped at 1", 2" & 3" for hose connection access in drop box)
HRS-254L	Same as HRS254 except stepped at 3" & 4"	HRS-354L	Same as HRS354 except stepped at 4", 5" & 6"

"H" Assemblies

"H" Assembly

- Eliminates internal threads where paint can collect and harden and contaminate paint job
- Modular construction
- Reduces installation cost
- Integral by-pass
- No jumper hoses required for flushing

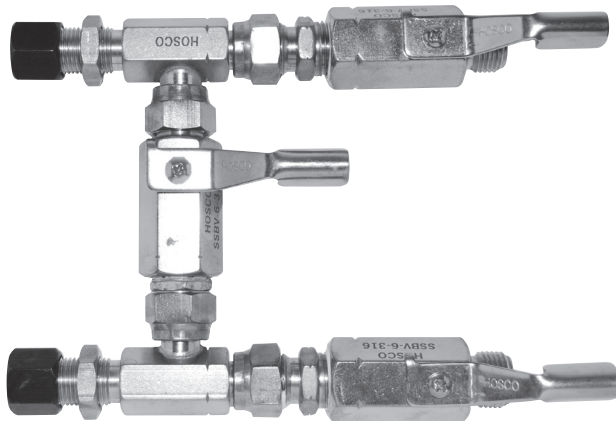

Bulkhead Models

PART NO.	DESCRIPTION
H-100A	3/8" BTF x 3/8" NPS(M)
H-150	3/8" BTF x 1/2" BTF x 3/8" NPS(M)
H-200	1/2" BTF x 3/8" NPS(M)

Bulkhead Tube Fitting x Tube Fitting Models

PART NO.	DESCRIPTION
H-600	3/8" BTF x 3/8" TF
H-601	1/2" BTF x 1/2" TF
H-602	10mm BTF x 10mm TF
H-603	12mm BTF x 12mm TF

3-Way Ball Valve



PART NO. 316 SERIES	DESCRIPTION
SSBV - 3	3/8" NPT(F) x 3/8" NPT(F) x 3/8" NPT(F)

Stainless Steel Hose Assembly

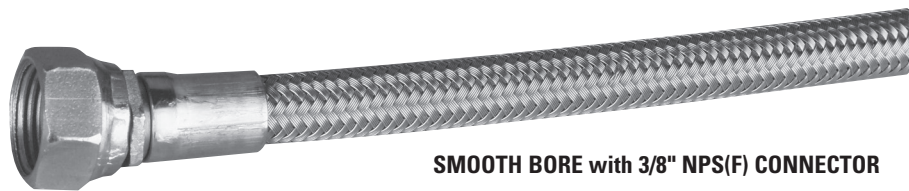

SMOOTH BORE with 3/8" NPS(F) CONNECTOR

SERIES TYPE	HOSE SIZE	CONNECTION DETAIL
PSH PSHC	08-1/2" 12-3/4" 16-1" 20-1-1/4" 24-1-1/2" 32-2"	A-Male NPT 316 SST B-Female JIC 313 SST D-Tri-Clamp End 316 SST (1", 1-001/2" or 2" Size Only) E-Male NPT Carbon Steel J-Female JIC Carbon Steel
PDH PDHC	06-3/8" 08-1/2" 12-3/4" 16-1" 20-1-1/4"	A-Male NPT 316 SST B-Female JIC 313 SST D-Tri-Clamp End 316 SST (1" Size Only) E-Male NPT Carbon Steel F-3/8" BSP(F) SST J-Female JIC Carbon Steel G-3/8" NPS(F) SST (3/8" and 1/2" Size Only) H-3/8" NPS(M) SST (3/8" and 1/2" Size Only) T-3/8" OD Tube Stub (3/8" and 1/2" Size Only)

Convuluted Hose

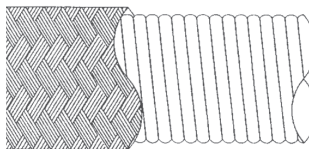

PSH – non-conductive, PTFE lined, fiberglass reinforced innercore, overbraided with 300 series stainless steel.
PSHC – conductive (carbon impregnated), PTFE lined, fiberglass reinforced innercore, overbraided with 300 series stainless steel.

Smooth Bore Hose

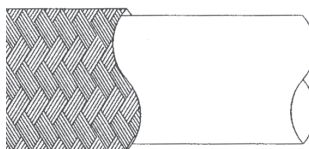

PDH – .030 wall, non-conductive virgin PTFE tubing, overbraided with 300 series stainless steel wire.
PDHC – .030 wall, conductive lined, virgin PTFE tubing, overbraided with 300 series stainless steel wire.

PART NUMBER CONFIGURATOR/SPECIFIER				
Series PSH, PSHC or PDH	Hose size XX	Connection detail		Overall length in inches XXX
Choose Convuluted or Smooth Bore from above	Choose hose size	End 1 X	End 2 X	Expandable length in inches end to end.

SAMPLE

PDH-08-AB-072 Hose is smooth bore (PDH)	1/2" size (08)	1/2" NPT (M) 316 SST connector one end (A)	1/2" JIC (F) 316 SST connector other end (B)	With overall length at 72" (072)
--------------------------------------------	----------------	--------------------------------------------	----------------------------------------------	----------------------------------

Nylon Paint Hose

Hosco NP nylon paint hose features Nylon-11 seamless extruded construction with inside and outside dimension held to close tolerances. Hosco NP is tough, lightweight, flexible, and resistant to water absorption. It can be used for all types of air and fluid applications and is unaffected by paint, enamel, lacquers, solvents, and water based material. NP hose is available in reels, and cut lengths. Consult Hosco for further information on temperature range, bend radius or other performance factors.



PART NO.	DESCRIPTION	WORKING PRESSURE @75°F
NP - 2	1/8" ID x .225 OD (3.2mm x 5.7mm)	325 PSI (22 BAR) 500 ft. Reel
NP - 3	3/16" ID x .264 OD (4.8mm x 6.7mm)	280 PSI (19 BAR) 500 ft. Reel
NP - 4	1/4" ID x .350 OD (6.35mm x 8.9mm)	250 PSI (17 BAR) 500 ft. Reel
NP-4TL	NP-4 Twin Line Bonded	250 PSI (17 BAR) 250 ft. Reel
NP-5	3/16" ID x .425 OD (8mm x 10.8mm)	240 PSI (15 BAR) 250 ft. Reel
NP-6	3/8" ID x .500 OD (9.5mm x 12.7mm)	240 PSI (15 BAR) 250 ft. Reel

Nylon Tubing

Hosco NHA series Nylon-11 tubing shares similar design and performance characteristics to the Hosco NP product line. NHA tubing can also be used for both air and paint and is available in both fractional inch and metric sizes. Available in colors. Check with local distributor.

We stock Nylon tubing in a limited number of colors. If you need any of our other standard colors (shown below), allow five weeks to fulfill your order.

Black: BL Silver: S Green: G Yellow: Y White: W
Brown: BR Red: R Blue: B Orange: OR Purple: P

PART NO.	DESCRIPTION	WORKING PRESSURE @75°F	WORKING PRESSURE @150°F	BEND RADIUS
NHA - 532 / NHA - 4 x 2.7	.106" ID x .025" Wall 2.7mm ID x 4mm OD	350 PSI 24 BAR	210 PSI 14 BAR	1/2" (12mm)
NHA - 0302	.138 ID x .025" Wall 3.5mm ID x 4.8mm OD	260 PSI 18 BAR	160 PSI 11 BAR	3/4" (19mm)
NHA - 6 x 4	.157" ID x .040" Wall 4mm ID x 6mm OD	340 PSI 23 BAR	200 PSI 13 BAR	1-1/4" (32mm)
NHA - 0403	.180" ID x .035" Wall 4.6mm ID x 6.35mm OD	290 PSI 20 BAR	170 PSI 11 BAR	1-1/4" (32mm)
NHA - 0504 / NHA - 8 x 6	.236" ID x .040" Wall 6mm ID x 8mm OD	240 PSI 16 BAR	140 PSI 9 BAR	1-1/2" (38mm)
NHA - 9 x 6	.236" ID x .0625" Wall 6mm ID x 9mm OD	250 PSI 17 BAR	150 PSI 10 BAR	2" (50mm)
NHA - 375275	.275" ID x .050" Wall 7mm ID x 9.6mm OD	250 PSI 17 BAR	150 PSI 10 BAR	2" (50mm)
NHA - 10 x 7	.275" ID x .059" Wall 7mm ID x 10mm OD	280 PSI 19 BAR	170 PSI 11 BAR	2-1/2" (65mm)
NHA - 10 x 8	.312" ID x .040" Wall 8mm ID x 10mm OD	190 PSI 13 BAR	110 PSI 7 BAR	2" (50mm)
NHA - 12 x 9 (250 ft. reel)	.354" ID x .059" Wall 9mm ID x 12mm OD	250 PSI 17 BAR	150 PSI 10 BAR	3" (76mm)
NHA - 12 x 10 (250 ft. reel)	.393" ID x .040" Wall 10mm ID x 12mm OD	150 PSI 10 BAR	90 PSI 6 BAR	2-1/2" (65mm)
NHA - 0806	3/8" ID x .500 OD (9.5mm x 12.7mm)	240 PSI 15 BAR	150 PSI 10 BAR	2" (50mm)

500 ft. minimum order per part number

877.852.7782



hosco.net

All Hosco products are certified silicone-free,
cleaned and ready for installation into paint systems.

Paint and Air Hoses

Coaxial Paint Hose

Hosco Coaxial Paint hose is specially compounded to withstand today's modern paints and solvents and has far greater flexibility for ease and movement than conventional nylon paint hose. CPH hose features a three-layer extrusion of a nylon inner tube, a polyurethane middle layer, and a nylon jacket. It is smooth and seamless with a natural translucent color. It is used primarily at handgun stations to improve ergonomics.



HOSCO CPH - 4

PART NO.	DESCRIPTION	WORKING PRESSURE
CPH - 4	1/4" ID x .350 OD (6.35mm x 8.9mm)	200 PSI (14 BAR)
CPH - 5	5/16" ID x .425 OD (8mm x 10.5mm)	190 PSI (13 BAR)
CPH - 6	3/8" ID x .500 OD (9.5mm x 12.7mm)	180 PSI (12 BAR)

Paint Hose Clips

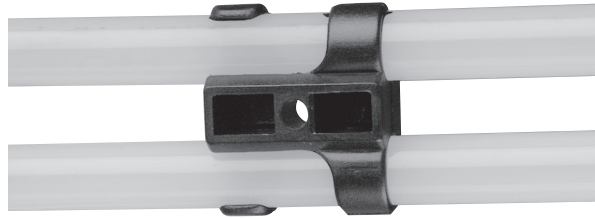

PART NO.	DESCRIPTION	FOR USE WITH
HTC - 201 - 325	Hose Clip	1/8" & 3/16" ID Nylon Paint Hose
HTC - 326 - 400	Hose Clip	1/4" & 5/16" ID Nylon Paint Hose
HTC - 401 - 485	Hose Clip	5/16" & 3/8" ID Nylon Paint Hose

Hose and Tubing Cutter

The Hosco Hose & Tubing Cutter will provide straight, clean accurate cuts for optimum fitting connections. The lightweight, rugged unit will cut 1/8" through 3/4" OD tubing. The exclusive "blade guard" feature provides protection from accidental blade contact. Ribbed handle aides in accurate positioning on the tube.



PART NO.	DESCRIPTION
PXC060	Hose/Tubing Cutter

Fluoropolymer Paint Hose

Hosco FEP Paint hose is constructed of FEP Fluoropolymer, which has excellent chemical resistance and dielectric properties, thermally superior to most other plastics, and flushes cleanly during color changing processes. It is also moisture proof, which makes it a good choice for two component paints or other moisture sensitive materials. Also, PTFE, MFA, and PFA tubing available, call for information.



Heavy Wall (.063) (Larger Sizes Available)

PART NO.	OD	ID	WORKING PRESSURE
FEP - 0402	1/4"	1/8"	450 PSI (31 BAR)
FEP - 0503	5/16"	3/16"	350 PSI (24 BAR)
FEP - 0604	3/8"	1/4"	290 PSI (20 BAR)
FEP - 0705	7/16"	5/16"	250 PSI (17 BAR)
FEP - 0806	1/2"	3/8"	210 PSI (14 BAR)

Sold in 50 ft. increments

Industrial Wall (.032)

PART NO.	OD	ID	WORKING PRESSURE
FEP - 0302	3/16"	1/8"	290 PSI (20 BAR)
FEP - 0403	1/4"	3/16"	210 PSI (14 BAR)
FEP - 0504	5/16"	1/4"	165 PSI (11 BAR)

Sold in 50 ft. increments

Heavy Wall (1.5mm)

PART NO.	OD	ID	WORKING PRESSURE
FEPM - 9 x 6	9mm	6mm	290 PSI (20 BAR)
FEPM - 10 x 7	10mm	7mm	250 PSI (17 BAR)
FEPM - 12 x 9	12mm	9mm	210 PSI (14 BAR)

Sold in 50 ft. increments

Industrial Wall (1mm)

PART NO.	OD	ID	WORKING PRESSURE
FEPM - 5 x 3	5mm	3mm	350 PSI (24 BAR)
FEPM - 6 x 4	6mm	4mm	290 PSI (20 BAR)
FEPM - 8 x 6	8mm	6mm	210 PSI (14 BAR)
FEPM - 10 x 8	10mm	8mm	165 PSI (11 BAR)

Sold in 50 ft. increments

Static Wire Air Hose

Hosco Static Wire Air hose is commonly used with air atomizing spray guns where the presence of static electricity requires grounding.

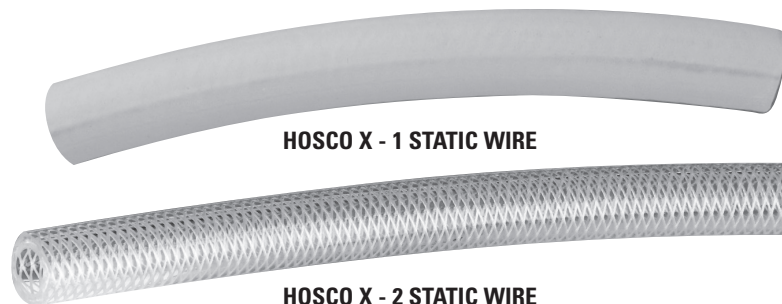

HOSCO X - 1 STATIC WIRE

HOSCO X - 2 STATIC WIRE

HOSE	ID (IN.)	OD (IN.)	WORKING PRESSURE	SERVICE	APPROX WT/CFT	NO SPRING GUARD		WITH SPRING GUARD	
						1/4" NPS(F)	3/8" NPS(F)	1/4" NPS(F)	3/8" NPS(F)
HOSCO X-1	5/16" (8mm)	5/8" (15.9mm)	200 PSI (13.6 BAR)	HD	13.8	HHC-4527	HHC-4547		
HOSCO X-2	(7.5mm)	15/32" (12mm)	200 PSI (13.6 BAR)	MD	9.7	X-2-14-SS	X-2-38-SS	X-2-14-SG	X-2-38-SG

Construction of X-1

Tube: EDPM
 Reinforcement: 2 and 4 spiral polyester yarn
 Cover: EDPM
 Cover Color: Yellow

Construction of X-2

Tube: Urethane
 Reinforcement: Dacron Braid
 Cover: Urethane
 Cover Color: Clear

Hose Connections

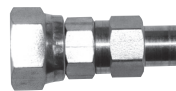

**NO SPRING GUARD
-B FOR BSP CONNECTION**



**WITH SPRING GUARD
-B FOR BSP CONNECTION**

Nylon Paint Hose and Air Tubing

HOSE ID	PART NO.	DESCRIPTION	WP	1/4" NPS(F)	3/8" NPS(F)	1/4" NPS(F)	3/8" NPS(F)
0.106" (2.7mm)	NHA-532	.106" ID x .025" Wall Nylon	275 PSI (19 BAR)	N/A	N/A	N/A	N/A
0.125" (3.2mm)	NP-2	1/8" ID x .050" Wall Nylon	325 PSI (22 BAR)	1814-SS	1838-SS	1814-SG	1838-SG
0.138" (3.5mm)	NHA-0302	.138" ID x .025" Wall Nylon	225 PSI (15 BAR)	1814-SS-187	1838-SS-187	1814-SG-187	1838-SG-187
0.157" (4mm)	NHA-6x4	4mm ID x 6mm OD Nylon	280 PSI (19 BAR)	4x6-14-SS	4x6-38-SS	4x6-14-SG	4x6-38-SG
0.180" (4.6mm)	NHA-0403	.180" ID x .035" Wall Nylon	250 PSI (17 BAR)	31614-SS-256	31638-SS-256	31614-SG-256	31638-SG-256
0.187" (4.8mm)	NP-3	3/16" ID x .040" Wall Nylon	280 PSI (19 BAR)	31614-SS	31638-SS	31614-SG	31638-SG
0.232" (6mm)	NHA-0504	.232" ID x .040" Wall Nylon	220 PSI (15 BAR)	6x8-14-SS	6x8-38-SS	6x8-14-SG	6x8-38-SG
0.232" (6mm)	NHA-8x6	.232" ID x .040" Wall Nylon	220 PSI (15 BAR)	6x8-14-SS	6x8-38-SS	6x8-14-SG	6x8-38-SG
0.236" (6mm)	NHA-9x6	6mm ID x 9mm OD Nylon	260 PSI (17 BAR)	6x9-14-SS	6x9-38-SS	6x9-14-SG	6x9-38-SG
0.250" (6.4mm)	NP-4	1/4" ID x .050" Wall Nylon	250 PSI (17 BAR)	1414-SS	1438-SS	1414-SG	1438-SG
0.275" (7mm)	NHA-375275	.275 ID x .050" Wall Nylon	220 PSI (15 BAR)	0714-SS	0738-SS	0714-SG	0738-SG
0.275" (7mm)	NHA-10x7	7mm ID x 10mm OD Nylon	240 PSI (16 BAR)	7x10-14-SS	7x10-38-SS	7x10-14-SG	7x10-38-SG
0.312" (7.9mm)	NP-5	5/16" ID x .050" Wall Nylon	220 PSI (15 BAR)	51614-SS	51638-SS	51614-SG	51638-SG
0.315" (8mm)	NHA-10x8	8mm ID x 10mm OD Nylon	180 PSI (12 BAR)	8x10-14-SS	8x10-38-SS	8x10-14-SG	8x10-38-SG
0.354" (9mm)	NHA-12x9	9mm ID x 12mm OD Nylon	180 PSI (12 BAR)	9x12-14-SS	9x12-38-SS	9x12-14-SG	9x12-38-SG
0.375" (9.5mm)	NHA-0806	3/8" ID x .063" Wall Nylon	220 PSI (15 BAR)	3814-SS	3838-SS	3814-SG	3838-SG
0.394" (10mm)	NHA-12x10	10mm ID x 12mm OD Nylon	165 PSI (11 BAR)	10x12-14-SS	10x12-38-SS	10x12-14-SG	10x12-38-SG

Coaxial Paint Hose

HOSE ID	PART NO.	DESCRIPTION	WP	1/4" NPS(F)	3/8" NPS(F)	1/4" NPS(F)	3/8" NPS(F)
0.250" (6.4mm)	CPH-4	1/4" ID x .050" Wall Coaxial	220 PSI (15 BAR)	1414-SS	1438-SS	1414-SG	1438-SG
0.375" (9.5mm)	CPH-6	3/8" ID x .063" Wall Coaxial	220 PSI (15 BAR)	3814-SS	3838-SS	3814-SG	3838-SG

FEP Fluoropolymer Paint Hose

HOSE ID	PART NO.	DESCRIPTION	WP	1/4" NPS(F)	3/8" NPS(F)	1/4" NPS(F)	3/8" NPS(F)
0.125" (3.2mm)	FEP-0302	1/8" ID x 3/16" OD FEP	290 PSI (20 BAR)	1814-SS-187	1838-SS-187	1814-SG-187	1838-SG-187
0.125" (3.2mm)	FEP-0402	1/8" ID x 1/4" OD FEP	450 PSI (30 BAR)	1814-SS-T	1838-SS-T	1814-SG-T	1838-SG-T
0.157" (4mm)	FEPM-6x4	4mm ID x 6mm OD FEP	290 PSI (20 BAR)	4x6-14-SS	4x6-38-SS	4x6-14-SG	4x6-38-SG
0.187" (4.8mm)	FEP-0403	3/16" ID x 1/4" OD FEP	210 PSI (15 BAR)	31614-SS-256	31638-SS-256	31614-SG-256	31638-SG-256
0.187" (4.8mm)	FEP-0503	3/16" ID x 5/16" OD FEP	350 PSI (24 BAR)	31614-SS-T	31638-SS-T	31614-SG-T	31638-SG-T
0.236" (6mm)	FEPM-8x6	6mm ID x 8mm OD FEP	210 PSI (15 BAR)	6x8-14-SS	6x8-38-SS	6x8-14-SG	6x8-38-SG
0.236" (6mm)	FEPM-9x6	6mm ID x 9mm OD FEP	290 PSI (20 BAR)	6x9-14-SS	6x9-38-SS	6x9-14-SG	6x9-38-SG
0.250" (6.4mm)	FEP-0504	1/4" ID x 5/16" OD FEP	165 PSI (11 BAR)	1414-SS-312	1438-SS-312	1414-SG-312	1438-SG-312
0.250" (6.4mm)	FEP-0604	1/4" ID x 3/8" OD FEP	290 PSI (20 BAR)	1414-SS-T	1438-SS-T	1414-SG-T	1438-SG-T
0.312" (7.9mm)	FEP-0705	5/16" ID x 7/16" OD FEP	250 PSI (17 BAR)	51614-SS-T	51638-SS-T	51614-SG-T	51638-SG-T
0.315" (8mm)	FEPM-10x8	8mm ID x 10mm OD FEP	165 PSI (11 BAR)	8x10-14-SS	8x10-38-SS	8x10-14-SG	8x10-38-SG
0.354" (9mm)	FEPM-12x9	9mm ID x 12mm OD FEP	210 PSI (15 BAR)	9x12-14-SS	9x12-38-SS	9x12-14-SG	9x12-38-SG
0.375" (9.5mm)	FEP-0806	3/8" ID x 1/2" OD FEP	210 PSI (15 BAR)	3814-SS-T	3838-SS-T	3814-SG-T	3838-SG-T

Fluid-all Fluid Hose

HOSE ID	PART NO.	DESCRIPTION	WP	1/4" NPS(F)	3/8" NPS(F)	1/4" NPS(F)	3/8" NPS(F)
0.250" (6.4mm)	71-280	NYLON TUBE , REINFORCED, WITH RUBBER COVER	500 PSI (34 BAR)	1414-SS-FA	1438-SS-FA	1414-SG-FA	1438-SG-FA

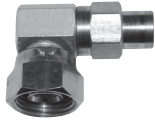

**NO SPRING GUARD
-B FOR BSP CONNECTION**

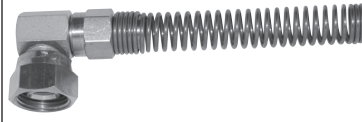

**WITH SPRING GUARD
-B FOR BSP CONNECTION**



**NO SPRING GUARD
-B FOR BSP CONNECTION**



**WITH SPRING GUARD
-B FOR BSP CONNECTION**

1/4" NPS(F)	3/8" NPS(F)	1/4" NPS(F)	3/8" NPS(F)	1/8" NPT(M)	1/4" NPT(M)	1/8" NPT(M)	1/4" NPT(M)
N/A	N/A	N/A	N/A	N/A	N/A	N/A	N/A
1814-SS-90	1838-SS-90	1814-SG-90	1838-SG-90	1818-T-SS	1814-T-SS	1818-T-SG	1814-T-SG
1814-SS-90-187	1838-SS-90-187	1814-SG-90-187	1838-SG-90-187	1818-T-SS-187	1814-T-SS-187	1818-T-SG-187	1814-T-SG-187
4x6-14-SS-90	4x6-38-SS-90	4x6-14-SG-90	4x6-38-SG-90	4x6-18-T-SS	4x6-14-T-SS	4x6-18-T-SG	4x6-14-T-SG
31614-SS-90-256	31638-SS-90-256	31614-SG-90-256	31638-SG-90-256	31618-T-SS-256	31614-T-SS-256	31618-T-SG-256	31614-T-SG-256
31614-SS-90	31638-SS-90	31614-SG-90	31638-SG-90	31618-T-SS	31614-T-SS	31618-T-SG	31614-T-SG
6x8-14-SS-90	6x8-38-SS-90	6x8-14-SG-90	6x8-38-SG-90	6x8-18-T-SS	6x8-14-T-SS	6x8-18-T-SG	6x8-14-T-SG
6x8-14-SS-90	6x8-38-SS-90	6x8-14-SG-90	6x8-38-SG-90	6x8-18-T-SS	6x8-14-T-SS	6x8-18-T-SG	6x8-14-T-SG
6x9-14-SS-90	6x9-38-SS-90	6x9-14-SG-90	6x9-38-SG-90	6x9-18-T-SS	6x9-14-T-SS	6x9-18-T-SG	6x9-14-T-SG
1414-SS-90	1438-SS-90	1414-SG-90	1438-SG-90	1418-T-SS	1414-T-SS	1418-T-SG	1414-T-SG
0714-SS-90	0738-SS-90	0714-SG-90	0738-SG-90	0718-T-SS	0714-T-SS	0718-T-SG	0714-T-SG
7x10-14-SS-90	7x10-38-SS-90	7x10-14-SG-90	7x10-38-SG-90	7x10-18-T-SS	7x10-14-T-SS	7x10-18-T-SG	7x10-14-T-SG
51614-SS-90	51638-SS-90	51614-SG-90	51638-SG-90	51618-T-SS	51614-T-SS	51618-T-SG	51614-T-SG
8x10-14-SS-90	8x10-38-SS-90	8x10-14-SG-90	8x10-38-SG-90	8x10-18-T-SS	8x10-14-T-SS	8x10-18-T-SG	8x10-14-T-SG
9x12-14-SS-90	9x12-38-SS-90	9x12-14-SG-90	9x12-38-SG-90	9x12-18-T-SS	9x12-14-T-SS	9x12-18-T-SG	9x12-14-T-SG
3814-SS-90	3838-SS-90	3814-SG-90	3838-SG-90	3818-T-SS	3814-T-SS	3818-T-SG	3814-T-SG
10x12-14-SS-90	10x12-38-SS-90	10x12-14-SG-90	10x12-38-SG-90	10x12-18-T-SS	10x12-14-T-SS	10x12-18-T-SG	10x12-14-T-SG

1/4" NPS(F)	3/8" NPS(F)	1/4" NPS(F)	3/8" NPS(F)	1/8" NPT(M)	1/4" NPT(M)	1/8" NPT(M)	1/4" NPT(M)
1414-SS-90	1438-SS-90	1414-SG-90	1438-SG-90	1418-T-SS	1414-T-SS	1418-T-SG	1414-T-SG
3814-SS-90	3838-SS-90	3814-SG-90	3838-SG-90	3818-T-SS	3814-T-SS	3818-T-SG	3814-T-SG

1/4" NPS(F)	3/8" NPS(F)	1/4" NPS(F)	3/8" NPS(F)	1/8" NPT(M)	1/4" NPT(M)	1/8" NPT(M)	1/4" NPT(M)
1814-SS-90-187	1838-SS-90-187	1814-SG-90-187	1838-SG-90-187	1818-T-SS-187	1814-T-SS-187	1818-T-SG-187	1814-T-SG-187
1814-SS-90-T	1838-SS-90-T	1814-SG-90-T	1838-SG-90-T	1818-T-SS-T	1814-T-SS-T	1818-T-SG-T	1814-T-SG-T
4x6-14-SS-90	4x6-38-SS-90	4x6-14-SG-90	4x6-38-SG-90	4x6-18-T-SS	4x6-14-T-SS	4x6-18-T-SG	4x6-14-T-SG
31614-SS-90-256	31638-SS-90-256	31614-SG-90-256	31638-SG-90-256	31618-T-SS-256	31614-T-SS-256	31618-T-SG-256	31614-T-SG-256
31614-SS-90-T	31638-SS-90-T	31614-SG-90-T	31638-SG-90-T	31618-T-SS-T	31614-T-SS-T	31618-T-SG-T	31614-T-SG-T
6x8-14-SS-90	6x8-38-SS-90	6x8-14-SG-90	6x8-38-SG-90	6x8-18-T-SS	6x8-14-T-SS	6x8-18-T-SG	6x8-14-T-SG
6x9-14-SS-90	6x9-38-SS-90	6x9-14-SG-90	6x9-38-SG-90	6x9-18-T-SS	6x9-14-T-SS	6x9-18-T-SG	6x9-14-T-SG
1414-SS-90-312	1438-SS-90-312	1414-SG-90-312	1438-SG-90-312	1418-T-SS-312	1414-T-SS-312	1418-T-SG-312	1414-T-SG-312
1414-SS-90-T	1438-SS-90-T	1414-SG-90-T	1438-SG-90-T	1418-T-SS-T	1414-T-SS-T	1418-T-SG-T	1414-T-SG-T
51614-SS-90-T	51638-SS-90-T	51614-SG-90-T	51638-SG-90-T	51618-T-SS-T	51614-T-SS-T	51618-T-SG-T	51614-T-SG-T
8x10-14-SS-90	8x10-38-SS-90	8x10-14-SG-90	8x10-38-SG-90	8x10-18-T-SS	8x10-14-T-SS	8x10-18-T-SG	8x10-14-T-SG
9x12-14-SS-90	9x12-38-SS-90	9x12-14-SG-90	9x12-38-SG-90	9x12-18-T-SS	9x12-14-T-SS	9x12-18-T-SG	9x12-14-T-SG
3814-SS-90-T	3838-SS-90-T	3814-SG-90-T	3838-SG-90-T	3818-T-SS-T	3814-T-SS-T	3818-T-SG-T	3814-T-SG-T

1/4" NPS(F)	3/8" NPS(F)	1/4" NPS(F)	3/8" NPS(F)	1/8" NPT(M)	1/4" NPT(M)	1/8" NPT(M)	1/4" NPT(M)
NA	NA	NA	NA	NA	NA	NA	NA

Monoline Coaxial Paint Circulating System

How the System Works

The system can be used on a conventional recirculating system to the gun. It replaces the conventional supply and return hoses with a single monoline coaxial paint hose which attaches to the supply and return paint station ball valve.

The Restrictor

HOSCO RIL-6 - an in-line restrictor identical to the RY-4 or 6 less the WYE recirculation feature.

The Hoses

The hoses are specially compounded to withstand solvents and paints and yet are more flexible than a conventional nylon paint hose, for ease of movement and operation. A hose within a hose.

The Connector

The system can be used on a conventional recirculating system to the gun. It replaces the conventional supply and return hoses with a single monoline coaxial paint hose which attaches to the supply and return paint station ball valve.

Advantages Over a Two Hose System

- More flexibility
- Ease of handling
- Less maintenance
- Less dirt or places for overspray to accumulate
- Less spaghetti (paint hoses) lying around the booth
- Less operator fatigue
- Better temperature control
- Less heat loss than conventional two hose system

The System: A hose within a hose.

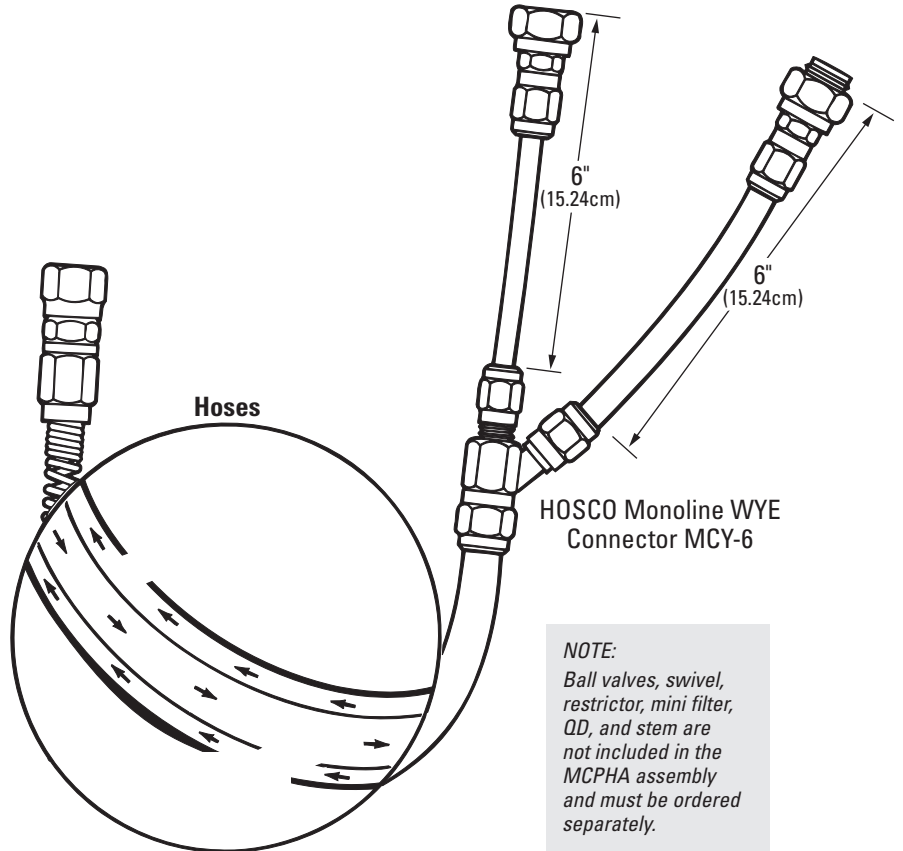

PART NO.	DESCRIPTION
MCPHA - 15	15' Hose Assembly with Fittings
MCPHA - 20	20' Hose Assembly with Fittings
MCPHA - 25	25' Hose Assembly with Fittings
MCPHA - 30	30' Hose Assembly with Fittings

NOTE:
For special lengths, metric connections, contact customer service.

ACCESSORIES

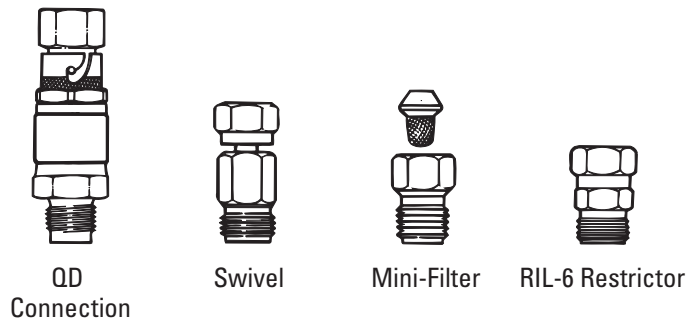

Tees and Manifold Fittings



PART NO.	DESCRIPTION
6SN - 6 - 4T(F) - 316	3/8" NPS(F) x 3/8" NPS(M) x 1/4" NPT(F)



PART NO.	DESCRIPTION
6SN - 6 - 6SN - 316	3/8" NPS(F) x 3/8" NPS(M) x 3/8" NPS(F)
6SNB - 6B - 6SNB - 316	3/8" BSP(F) x 3/8" BSP(M) x 3/8" BSP(F)



PART NO.	DESCRIPTION
6SN - 6 - 4T - 316	3/8" NPS(F) x 3/8" NPS(M) x 1/4" NPT(M)
6SN - 6 - 6T - 316	3/8" NPS(F) x 3/8" NPS(M) x 3/8" NPT(M)



PART NO.	DESCRIPTION
6SN - 6TF - 4T(F) - 316	3/8" NPS(M) x 3/8" OD TF x 1/4" NPT(F)
6SN - 6BTF - 6SN - 316	3/8" NPS(F) x 3/8" OD Bulkhead TFS x 3/8" NPS(F)

Stainless Steel Check Valves

- Stainless steel
- Compact
- Use on return line in recirculating system

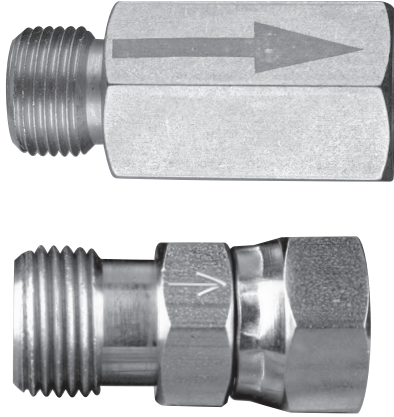

PART NO.	DESCRIPTION
SSCV - 6	3/8" NPS(M) x 3/8" NPT(F)
SSCV - 6B	3/8" BSP(M) x 3/8" BSPT(F)
SSCV - 6T	3/8" NPT(M) x 3/8" NPT(F)
SSCV - 6BT	3/8" BSPT(M) x 3/8" BSPT(F)
CV - 6 - RK	Repair Kit includes ball, spring, and O-ring

Cracking Pressure 3.5 PSI

PART NO.	DESCRIPTION
6SN - 6CV	3/8" NPS(F) x 3/8" NPS(M)

Cracking Pressure 1.5 PSI

Hose Splicers/Bulkhead Hose Splicers

- Quickly mends broken hose
- Joins multiple size hose
- Compact design

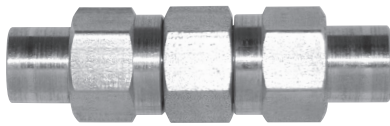

- For panel, wall, or plate mounting
- Compact design

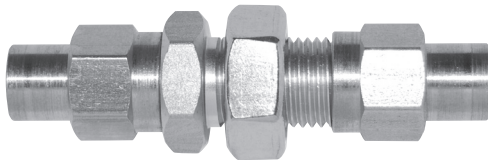

PART NO.	DESCRIPTION
1414 - HSP	1/4" ID x .350 OD Splicer
3838 - HSP	3/8" ID x .500 OD Splicer
6x8 - 6x8 - HSP	6mm ID x 8mm OD Hose Splicer
6x9 - 6x9 - HSP	6mm ID x 9mm OD Hose Splicer
7x9.6 - 7x9.6 - HSP	7mm ID x 3/8" OD Hose Splicer
7x10 - 7x10 - HSP	7mm ID x 10mm OD Hose Splicer

PART NO.	DESCRIPTION
6868 - SSBH	6mm ID x 8mm OD Bulkhead Splicer
6969 - SSBH	6mm ID x 9mm OD Bulkhead Splicer
7x9.6 - 7x9.6 - SSBH	7mm ID x 3/8" OD Bulkhead Splicer
7x10 - 7x10 - SSBH	7mm ID x 10mm OD Bulkhead Splicer

Hose Sweeps, Bulkheads, Strain Reliefs and Gun Extensions

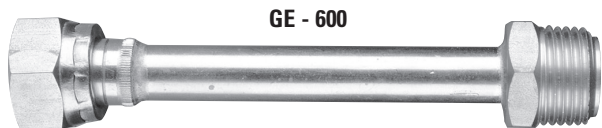

GE - 600



GE - 630

PART NO.	DESCRIPTION
GE - 600	3/8" NPS(F) x 3/8" NPS(M) x 3-3/4"
GE - 600 - B	3/8" BSP(F) x 3/8" BSP(M) x 3-3/4"
GE - 630	3/8" NPS(F) x 3/8" NPS(M) x 30° x 3-3/4"
GE - 630 - B	3/8" BSP(F) x 3/8" BSP(M) x 30° x 3-3/4"

Hose Sweeps, Bulkheads, Strain Reliefs



PART NO.	DESCRIPTION
SSL4 - 4SN - 90	1/4" NPS(M) x 1/4" NPS(F) x 90°
SSL6 - 6SN - 90	3/8" NPS(M) x 3/8" NPS(F) x 90°
SSL6B - 6SNB - 90	3/8" BSP(M) x 3/8" BSP(F) x 90°

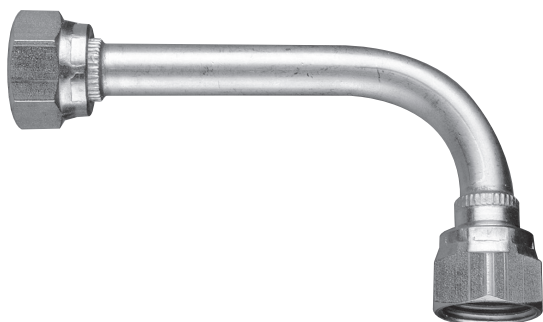

PART NO.	DESCRIPTION
SSL6SN - 6SN - 90	3/8" NPS(F) x 3/8" NPS(F) x 90°
SSL6SNB - 6SNB - 90	3/8" BSP(F) x 3/8" BSP(F) x 90°

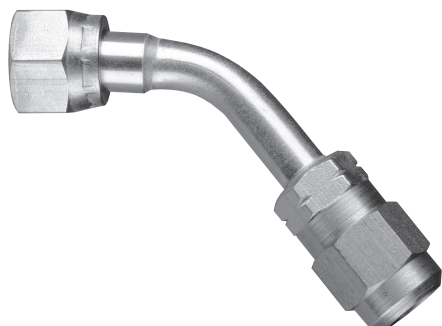

PART NO.	DESCRIPTION
6 - 9 x 4 - 45SS - 316	6mm ID x 9mm OD x 45° x 1/4" NPS(F)
6 - 9 x 4B - 45SS - 316	6mm ID x 9mm OD x 45° x 1/4" BSP(F)
6 - 8 x 4 - 45SS - 316	6mm ID x 8mm OD x 45° x 1/4" NPS(F)
6 - 8 x 4B - 45SS - 316	6mm ID x 8mm OD x 45° x 1/4" BSP(F)

PART NO.	DESCRIPTION
6 - 9 x 4 - 60SS - 316	6mm ID x 9mm OD x 60° x 1/4" NPS(F)
6 - 9 x 4B - 60SS - 316	6mm ID x 9mm OD x 60° x 1/4" BSP(F)
9 - 12 x 4 - 60SS - 316	9mm ID x 12mm OD x 60° x 1/4" NPS(F)
9 - 12 x 4B - 60SS316	9mm ID x 12mm OD x 60° x 1/4" BSP(F)

IMAGINEERING... HOSCO STYLE.
 Sometimes great ideas start on a scrap of paper.

We pride ourselves in solving some of the toughest problems in the paint delivery industry. But those solutions don't necessarily start here. Many of them start with our customers giving us an idea on a scrap of paper... "What if we do this?" "What if we do it this way?"

The photo to the right shows bulkhead ball valve assemblies acting as "T" configurations enabling the supply and return hoses from the robot assemblies to terminate at a single paint station. Pressure drop is reduced by 50%.

All the items below started with an idea on a scrap of paper. Send us your ideas. We'll make it work. We'll solve the problem. Engineer it. Prototype it. Produce it!

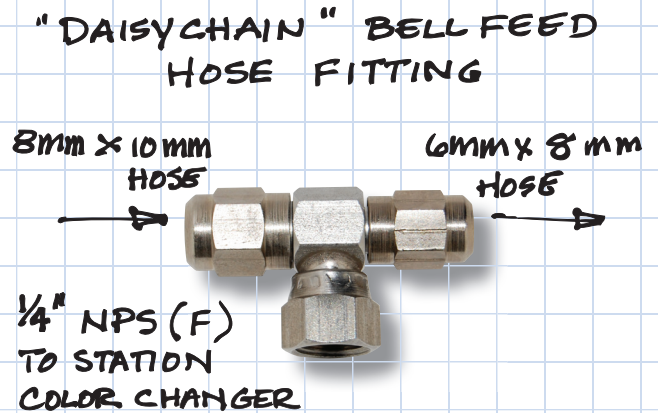
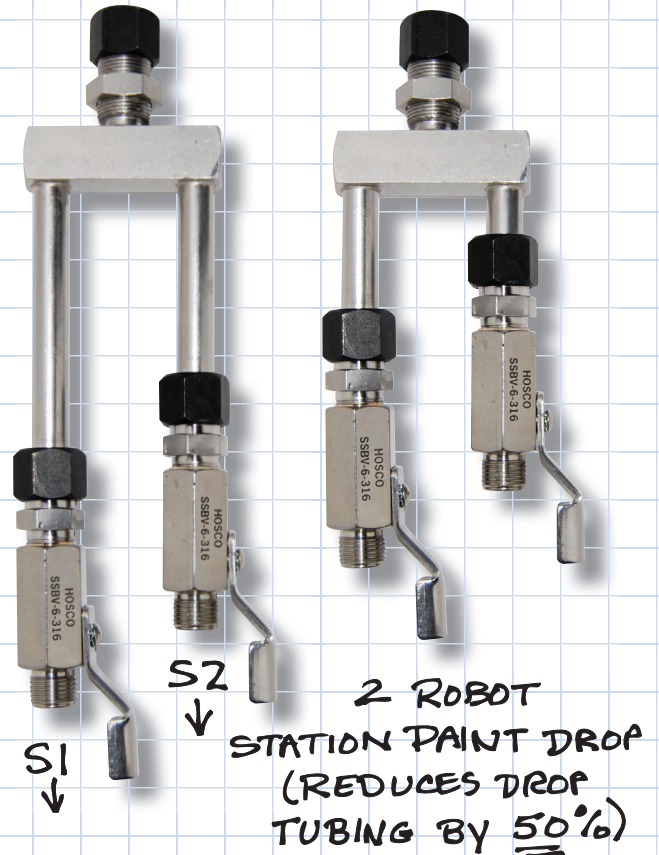
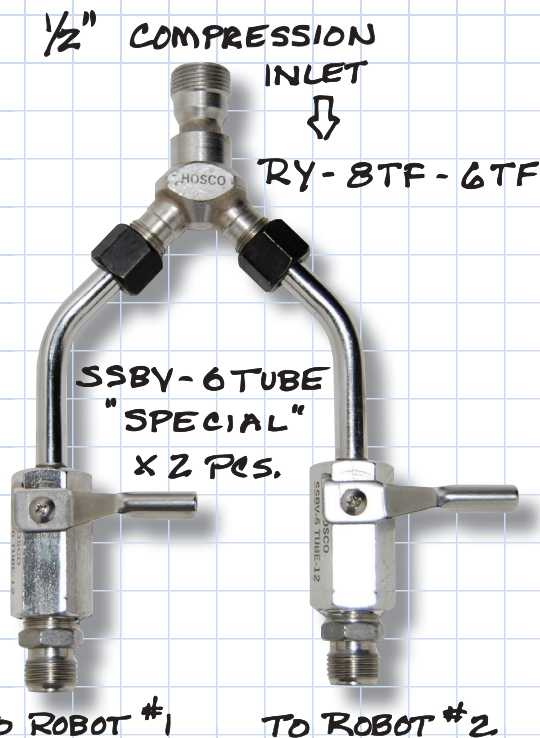
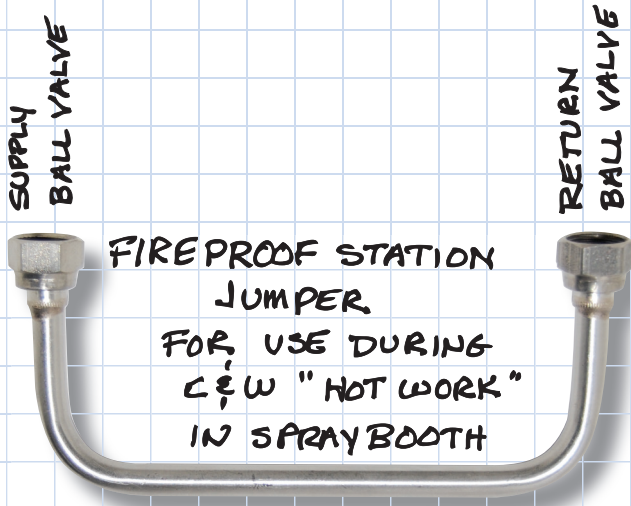



6" LONG WITH
3/8" BULKHEAD
COMPRESSION
AND 3/8" NPS(M)
HOSE CONNECTION
END

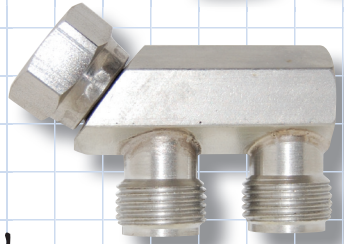
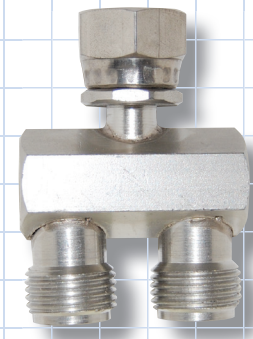
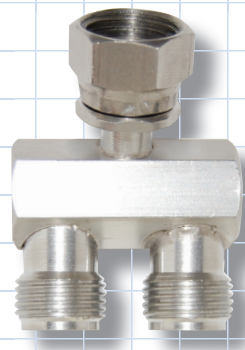

SPECIAL
"WORK ORDER"
CIRCULATION ADAPTERS
AND FLOW RESTRICTORS
FOR SPRAYGUNS AND
COLOR CHANGERS
AROUND THE WORLD

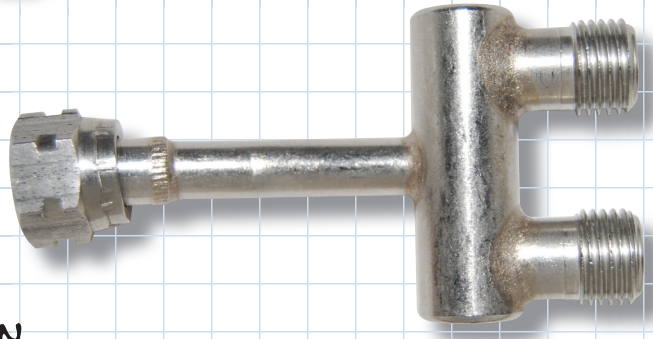

PAINT STATION
"SPLITTER"
IN 1/2" OR 5/8" SIZES

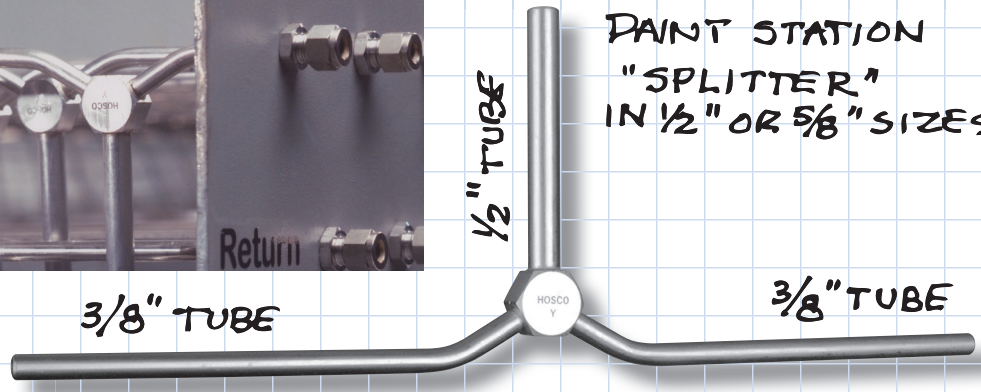

3/8" TUBE

1/2" TUBE

3/8" TUBE

**At Hosco
we think
globally but
act locally.**

Hosco is a finishing system components manufacturer serving the finishing industry worldwide through systems integrators, and an extensive network of regional authorized distributors and agents. Hosco offers standardized capability for circulation systems and application finishing on a Global basis while being the only supplier of both inch and metric smooth-bore, cavity free and microfinished valves and fittings designed specifically for paint. All Hosco products are certified "silicone free" and ready for installation in your paint systems.

Hosco stands ready with the products, the service, and the expertise to deliver clean, contaminate-free paints and coatings... whether you are located next door or on the other side of the world.

ISO 9001:2008



28026 Oakland Oaks Court
Wixom, MI 48393

Phone: 248.912.1750
Toll free: 855.GO HOSCO (464.6726)
FAX: 248.912.1751

www.hosco.net
For questions: info@hosco.net
For ordering: orders@hosco.net

All Hosco Products Listed In This
Catalog Are Registered Under:

ISO-9001:2008 Certificate No. 0035961
Canadian Registration No. OC10249.5