



AA1500 AIR-ASSISTED AIRLESS SPRAY GUN (WITH AA10 AIR AIR CAP AND FAN SIZE ADJUSTMENT FEATURE)

Ex II 2 G X

The following instructions provide the necessary information for the proper operation and preventive maintenance of the Binks AA1500 Air-Assisted Airless Spray Gun. Please read and understand all information in this document in order to get the maximum performance from your new AA1500 spray gun.

In the AA1500 spray gun, the paint or other material to be sprayed is preatomized and forced through the carbide tip by the typical 400-800 psi fluid pressure (with capabilities up to 1500 psi/105 bar). As a result of the preatomizing, the final shaping air supplied by the air cap produces an exceptionally fine and even spray pattern. The result of this spray pattern is an even finish that lends itself to products that need an exceptionally fine finish with reduced overspray and VOC emissions.

SPECIFICATIONS:

Maximum Fluid Pressure:	1500 psi/105 bar
Maximum Air Pressure:	100 psi/6.8 bar
Gun Body:	Forged Aluminum
Fluid Path:	Stainless Steel
Fluid Shut Off Type:	Stainless Steel Ball, Standard UHMW Seat or optional Tungsten Carbide
Fluid Inlet Size:	1/4" NPS(m) Thread
Air Inlet Size:	1/8" NPT(m) x 3/8" O.D. Push In Tube Fitting
Gun Weight:	16-oz.

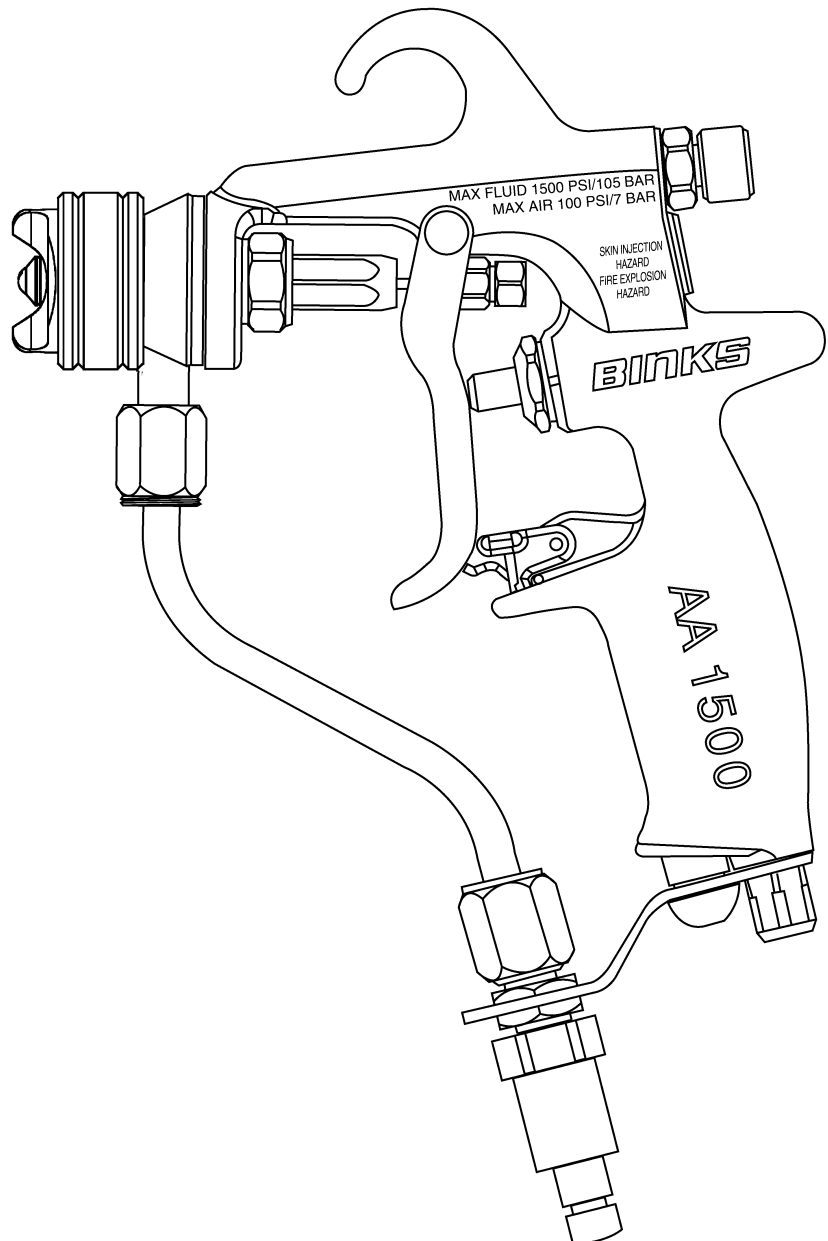

Product shown is covered by U.S. patent No. 6,276,616. Foreign patents are issued or pending.

Replaces
Part Sheet
77-2838R-1

Part
Sheet
77-2838R-2

⚠ WARNING



HIGH PRESSURE CAN CAUSE SERIOUS INJURY IF EQUIPMENT IS INSTALLED OR USED INCORRECTLY—

READ, UNDERSTAND, AND OBSERVE ALL WARNINGS AND INSTRUCTIONS IN THIS MANUAL.

OPERATE EQUIPMENT ONLY AFTER ALL INSTRUCTIONS ARE CLEARLY UNDERSTOOD.

In this part sheet, the words **WARNING**, **CAUTION** and **NOTE** are used to emphasize important safety information as follows:

⚠ WARNING
Hazards or unsafe practices which could result in severe personal injury, death or substantial property damage.

⚠ CAUTION
Hazards or unsafe practices which could result in minor personal injury, product or property damage.

NOTE
Important installation, operation or maintenance information.

INJECTION HAZARD

Spray from the gun, hose leaks, or ruptured components can inject fluid into your body and cause extremely serious injury, including poisoning or the need for amputation. Splashing fluid in eyes or on skin can also cause a serious injury.

- Fluid injected into the skin might look like just a cut, but is a serious injury and should be treated as such. **GET IMMEDIATE MEDICAL ATTENTION. INFORM THE PHYSICIAN WHAT TYPE OF MATERIAL WAS INJECTED.**
- Do not point the spray gun at anyone or any part of the body.
- Do not put fingers or hand over the spray tip.
- Do not stop or detect fluid leaks with a rag, hand, body or glove.
- Do not use a rag to blow back fluid. **THIS IS NOT AN AIR SPRAY GUN.**
- Engage the gun safety when not spraying.
- **ALWAYS RELIEVE THE PRESSURE WHENEVER WORKING ON THE SPRAY GUN.**
- Tighten all fluid connections before operating equipment.
- Check all hoses, tubes, and couplings daily. Replace all worn, damaged, or loose parts immediately.

Hazardous fluids or toxic fumes can cause serious injury or death if splashed on skin or in the eyes, swallowed or inhaled.

TOXIC FLUID HAZARD

- Know the specific hazards of the fluid you are using. This information is on the MSDS for the material being used. Read all fluid manufacturer's warnings.
- Store hazardous fluids in approved containers only. Dispose of all hazardous fluids in accordance with all state, local and national guidelines.
- Wear the appropriate protective clothing, gloves, eyewear and respirator.

Equipment misuse can cause the equipment to fail, malfunction, or start unexpectedly and result in serious injury.

EQUIPMENT MISUSE HAZARD

- This equipment is for professional use only.
- Read and understand all instructional manuals, tags, and labels before operating equipment.

- Use the equipment only for its intended purpose. If you are unsure about its purpose call your local Binks distributor.
- Do not alter or modify this equipment. Use only genuine Binks parts.
- Do not exceed the maximum working pressure of the lowest rated system component. **THE MAXIMUM RATING OF THE AA1500 IS 1500 PSI (105 BAR) FLUID PRESSURE. DO NOT EXCEED THE FLUID PRESSURE RATING.**
- Route all hoses away from all sharp edges, moving parts, hot surfaces and high traffic areas.
- Do not use hoses to pull the equipment.
- Use only Binks approved hoses. Do not remove spring guards from hoses, these are on the hoses to prevent rupture from kinking at the connectors.
- Use only solvents compatible with hoses and wetted parts of the equipment used.
- Comply with all applicable local state and national fire, electrical, and other safety regulations.

Improper grounding, poor air ventilation, open flames, or sparks can cause a hazardous condition and result in fire or explosion and cause serious injury.

FIRE AND EXPLOSION HAZARD

- Ground the equipment and object being sprayed.
- Provide fresh air ventilation to avoid the build up of flammable fumes from the material being sprayed or from solvent.
- Extinguish all open flames or pilot lights in spray area.
- Electrically disconnect all equipment in the spray area.
- Keep the spray area free from all debris, including solvent rags.
- If there is any static sparking while using the equipment, **STOP SPRAYING IMMEDIATELY.** Identify and correct problem.

NOISE LEVELS

- The A-weighted sound level of spray guns may exceed 85 dB(A) depending on the setup being used. It is recommended that ear protection is worn at all times when spraying.

The Spray Gun models listed in the following declaration of conformity may be used in some potentially explosive atmospheres **ONLY** when the special conditions for safe installation and operation have been followed as expressed in this user manual (Part Sheet). These models are approved to ATEX regulations 94/9/EC, protection level: **II 2 G X: Suitable for use in Zones 1 and 2.**

EC Declaration of Conformity		
Manuf. By:	ITW Industrial Finishing 195 Internationale Blvd. Glendale Heights, IL 60139	
Type/Series:	Manifold Mounted Automatic Spray Guns	
Model:	AA1500, AA4000	
The equipment to which this document relates is in conformance with the following standards or other normative references:		
EN ISO 12100-1&2:2003 and BS EN 1953:1999 and thereby conform to the protection requirements of Council Directive 98/37/EC relating to Machinery Safety Directive, and;		
EN 13463-1:2001 , Council Directive 94/9/EC relating to Equipment and Protective Systems for use in Potentially Explosive Atmospheres , protection level II 2 G X.		
Approved By:	 Chuck McCulloch, ITW Industrial Finishing	Date: <u>November 19, 2007</u>

SPRAY GUN SET-UP

1. Connect your high-pressure airless fluid hose to the gun fluid inlet and tighten securely.
2. Connect your air hose to the gun air connection and tighten securely.
3. Using the control knob of the fluid regulator, set the fluid pressure at the gun's lower end of the pressure range. A typical starting fluid pressure is 350 psi. Actual starting pressure points may be higher or lower than 350 psi and depend on the setup including the type of pump used, the type of material sprayed, and the spray gun itself.
4. Using the control knob on the air regulator, set the air pressure at zero.
5. To test the spraying pattern, spray a piece of wood or cardboard with a fast pass about one foot away from the piece. The results of the test will allow you to determine the uniformity of the particle size and spraying pattern.
6. If the spraying pattern develops tails or is not uniform, gradually increase the air pressure as necessary to develop a uniform spraying pattern. Typically, 10 psi air pressure is adequate. The air is used to assist the atomization of the coating.
7. If the quality of spray is acceptable, begin spraying. If the spraying rate is too slow to keep up with the production line speed, or if the quantity of material sprayed is inadequate for acceptable coverage, gradually increase the fluid pressure in 50 psi increments using the fluid regulator control knob. However, note that as the fluid pressure increases, more air is needed to eliminate the tails.

Consistency in spraying can be increased across spray gun operators and similar spraying jobs by developing pressure standardization charts. Repeat step 6 until the required material coverage and spraying speed are achieved. If the maximum fluid pressure is reached before the required material coverage and spraying speed are achieved, you may need to switch to a larger fluid tip.

TYPICAL HOOK-UP

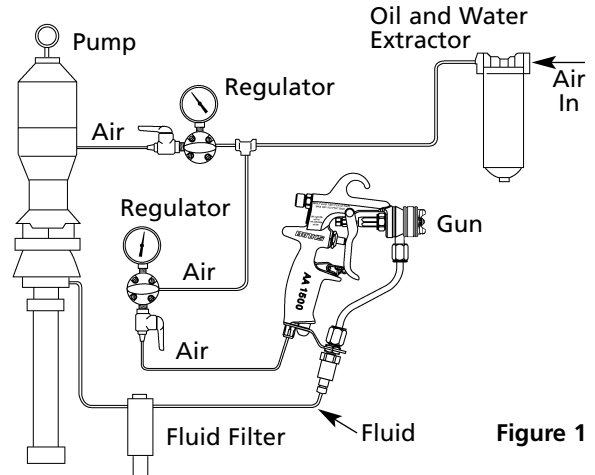

Figure 1

Fan pattern adjustment: turn knob counterclockwise to increase pattern; clockwise to decrease pattern (Fig. 2).

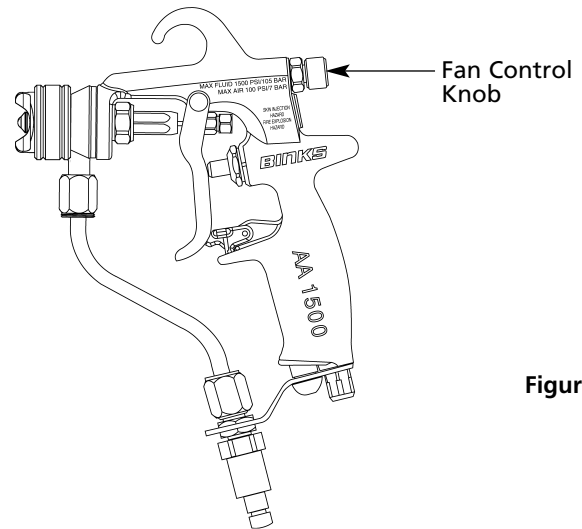

Figure 2

NOTE

Fan adjustment feature requires approximately 25 psi or higher of air inlet pressure. This is recommended for fluid pressures lower than 500 psi. Higher fluid pressure requires higher air inlet pressures to accommodate pattern adjustment.

FLUID TIP SELECTION

Factors to consider in selecting a fluid tip for an air-assisted airless spray gun include (1) the size of the parts being sprayed; (2) the production line speed; (3) the material flow rate and film thickness; (4) the viscosity of the material applied; (5) the type of material applied; and

(6) the quality of atomization of the coating required. The selection of a fluid tip necessary to perform a specific spraying job is best determined through a combination of experimentation and expert advice from your material and equipment suppliers.

FLUID HOSES

Air-assisted airless spray guns operate at fluid pressures higher than operating pressures of air spray guns. As a result, when operating an air-assisted airless spray gun, it

is critical to select the appropriate fluid hose that is rated for the pressure range at which the airless gun is operated.

TROUBLESHOOTING DEFECTIVE SPRAY PATTERNS

The following procedure summarizes the steps that an operator must immediately take when the first signs of a defective spray pattern emerge.

1. Check the external portion of the fluid tip for material buildup. If buildup has occurred, secure the gun trigger safety switch and clean the gun fluid tip with a non-metal soft brush.
2. If the spray pattern exhibits signs of tails at the top or bottom ends of the pattern, increase the air pressure gradually until the tails disappear.
3. If increasing air pressure does not dissipate the tails, the fluid tip may be worn and may need to be replaced. Another sign of the need to replace a worn tip is a gradual decline in spraying pattern width.

4. If cleaning or replacing the fluid tip does not dissipate the tails; the spraying defect is most likely due to the material temperature and/or viscosity.
5. If pattern pulsation or blinking occurs, check the pressure regulators, all downstream regulators, and the pump. These may require further adjustment or even repairs.

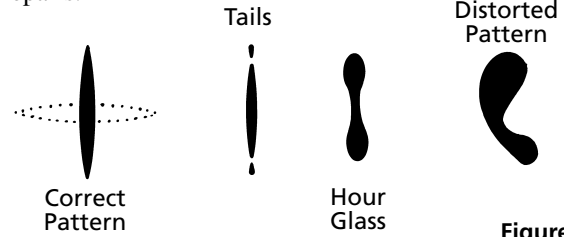

Figure 3

GENERAL TROUBLESHOOTING



PROBLEM	CAUSE	ACTION
Fluid leaking from the back of seal cartridge assembly (8)	Worn seal or needle shaft.	Replace needle packing cartridge (7).
Fluid leaking from the front of the gun	Needle ball worn or damaged. Worn seat assembly.	Replace needle packing cartridge (7). Replace fluid seat (3).
Fluid in air passages	Spray tip seal leaking. Leaking around fluid seat.	Tighten AA10 air cap assembly (1) Replace carbide tip assembly (2). Tighten or replace fluid seat (3).
Slow fluid shut off	Fluid buildup on cartridge assembly.	Clean or replace cartridge assembly (7).
No fluid output when triggered	Tip orifice plugged. Collet on needle has slipped. Fluid filter or fluid hose plugged.	Turn off fluid supply. Relieve pressure into a closed-grounded container. Engage trigger safety. Remove AA10 air cap assembly (1) and the carbide tip (2). Clean or replace carbide tip assembly (2). Turn off fluid supply. Relieve pressure into a closed-grounded container. Remove trigger (19). Remove needle packing cartridge (7). Loosen collet and move until the needle is flush with the rear of the collet. Tighten collet. Turn off fluid supply. Relieve pressure into a closed-grounded container. Turn off air supply to pump and relieve fluid pressure with by pass valve. Engage trigger safety. Very slowly loosen the hose connection at the gun to relieve any pressure in hose. Remove hose and clear obstruction.

IMPORTANT REGULATORY NOTE

The AA-1500 Air-Assisted H.V.L.P. hand spray gun combines the proven efficiency of the Binks compliant spray guns with air-assisted atomization to yield a reliable, carefully engineered compliant spray gun. With 25' of 5/16" I.D. air hose and regulator set at only 20 p.s.i. the compliant air cap registers 10 p.s.i. of atomization air to shape and soften the spray pattern. The AA-1500 air-assisted H.V.L.P. gun operates at high transfer efficiencies and fully complies with all government regulations for H.V.L.P. spray guns.

	Max. Fluid Input:	1500 p.s.i.
Max. static air pressure at regulator with 25' of hose to inlet:	20 p.s.i.	
Max. Dynamic Gun Inlet Air Pressure:	15 p.s.i.	
	Gun Body:	Forged Aluminum Alloy
	Fluid Path:	Stainless Steel and Tungsten Carbide

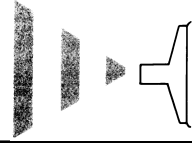
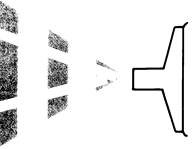
SPRAY PATTERN TROUBLESHOOTING

PROBLEM	CAUSE	ACTION
Fluttering Spray Pattern 	Insufficient fluid supply. Air in paint supply line. Attempting to "feather" (Partially trigger gun).	Adjust fluid regulator or fill fluid supply tanks. Check and tighten pump siphon hose connections, bleed air from paint line. Cannot feather with an AA1500 gun.
Striping Spray – Fingers 	Carbide tip partially plugged.	Clean or replace carbide tip assembly.
Irregular Pattern 	Fluid builds up on carbide tip, or tip partially plugged. On defective side of pattern, air horn holes are plugged.	Clean carbide tip. Clean air horn holes with solvent and a soft brush.
Pattern pushed to one side, same side of air cap gets dirty 	On defective side of pattern, air horn holes are plugged.	Clean air horn holes with solvent and a soft brush or toothpick.

AIR-ASSISTED AIRLESS SPRAY GUN MAINTENANCE AND CLEANING

Maintenance of air-assisted airless spray guns includes (1) fluid tip wear and replacement; (2) lubrication; and (3) cleaning of the gun.

FLUID TIP

Operating an air-assisted airless spray gun with a worn fluid tip will result in increased usage of spraying material and therefore, HAP emissions. For example, an increase in the diameter of a tip from 0.015 inch to 0.021 inch due to wear can result in up to a 100 percent increase in material consumption and cost. To prevent waste in spraying material and non-value-adding costs, a maintenance schedule that includes fluid tip inspection and replacement must be established.

LUBRICATION

Proper lubrication is essential for optimum spray gun performance. Lubrication allows the equipment to operate easily and correctly. The spray gun should be lubricated after each cleaning. The points that need lubrication during the maintenance of air-assisted airless spray guns include (1) the fluid needle packing; (2) trigger pivot point. Gun lube is used to lubricate the fluid needle packing and trigger pivot point.

⚠ CAUTION

Never immerse the entire gun in solvent or thinners. Some gun parts will lose their lubricative film and wear more quickly. Additionally, solvents may carry impurities throughout the gun body and allow them to clog small air and fluid passages.

CLEANING

The following steps summarize the procedure for cleaning air-assisted airless spray guns:

1. Turn off the shaping air supply.
2. Turn off the spraying material pump.
3. Place the pick-up tube from the pump in a solvent container and turn the pump on.

NOTE

Only use solvent identified as approved for cleaning and wash-off use.

4. Secure the gun trigger safety switch, remove the fluid tip, and place it in a closed solvent container.
5. Release the gun trigger safety switch and spray into a closed container until the fluid runs clear.

NOTE

During cleaning, the gun may only be sprayed into a closed container. never flush the gun into the air or spray booth.

6. Using a rag dampened with solvent, wipe the exterior surface of the gun. Additionally, some solvents are prohibited from being used for cleaning. The operator must take care to use only approved cleaning solvents for equipment cleaning. These materials are clearly labeled as approved for cleaning and wash off operations. If the operator has any question on selecting appropriate cleaning solvents, the operator should consult a supervisor or plant environmental staff.

⚠ WARNING

Failure to reduce pump air supply pressure or to use a closed container can result in material "bounce-back". Material "bounce back" can cause injury and damage.

WIRE AND BALL ASSEMBLY AND SEAT REPLACEMENT

Refer to assembly drawing on page 7 to locate numbered items.

1. Engage the trigger safety.
2. Shut off fluid pump and disconnect its air or power supply.
3. Release pressure from the entire fluid system, from the pump to the spray gun.
4. Remove AA10 air cap assembly (1) and spray tip (2).

Remove trigger (19) by removing the trigger stud (12) and the trigger screw (11).

5. Remove the AA1500 needle packing cartridge (7).
6. Carefully install new AA1500 needle packing cartridge (7).
7. Remove fluid seat (3) and o-ring.
8. Install new fluid seat (3) and o-ring.
9. Reinstall trigger (19), trigger stud (12) and trigger screw (11).

AIR VALVE REPLACEMENT

1. Engage the trigger safety.
2. Shut off fluid pump and disconnect its air or power supply.
3. Release pressure from the entire fluid system, from the pump to the spray gun.
4. Remove AA10 air cap assembly (1) and spray tip (2).

5. Remove trigger (19) by removing the trigger stud (12) and the trigger screw (11).
6. Remove air valve assembly (20).
7. Replace air valve assembly (20).
8. Reinstall trigger (19), trigger stud (12) and trigger screw (11).

PARTS LIST

When ordering, please specify Part No.
(Not all Part numbers are available for purchasing)

ITEM NO.	PART NO.	DESCRIPTION	QTY.	ITEM NO.	PART NO.	DESCRIPTION	QTY.
1	54-5346▼	AA10 AIR CAP ASSEMBLY	1	13	—	FLAT PLUG	1
1A	20-6784	FLUOROELASTOMER SEAL (2-015)	1	14	54-4947	FLUID TUBE BRACKET SPACER	1
1B	54-5348★	AA10 RETAINING RING (Stage 1)	1	15	54-4943	FLUID TUBE BRACKET	1
		(Part of 54-5346)		16	54-4975	PUSH IN TUBE FITTING	1
1C	54-5349★	AA10 RETAINING RING (Stage 2)	1			1/8" NPT(M) X 3/8" O.D.	
		(Part of 54-5346)		17	20-6718	BUTTON HEAD CAP SCREW	1
1D	54-5346	AIR CAP LESS RING	1	18	54-4944●	FLUID INLET FITTING	1
2	114-0XXXX	CARBIDE TIP ASSEMBLY	1	19	54-4937	TRIGGER	1
		(See Tip Selection Chart, pg. 8)		20	54-4909*	AIR VALVE ASSEMBLY	1
3	54-4926*▼	FLUID SEAT (UHMW Standard or	1	21	71-28▲	D.M. NIPPLE	1
		Optional Carbide Fluid Seat 54-4960)				1/8" NPT(m) x 1/4" NPS(m)	
3A	20-6037■	O-RING (Part of 54-4926)	1	22	54-4725	FILTER ASSEMBLY (100 Mesh)	1
4	54-4906	FLUID TUBE ASSEMBLY	1				
5	54-4924	GUN HEAD	1				
6	54-4923*	FRONT HEAD GASKET	1				
7	54-4908*	NEEDLE PACKING CARTRIDGE	1				
		(1,500 PSI maximum)					
8	—	GUN BODY (Not Sold Separately)	1				
9	54-4925	FLUID INLET NUT	1				
10	54-5328	SIDE PORT CONTROL ASS'Y(AA10) ..	1				
10A	20-6785	FLUOROELASTOMER SEAL (2-004)	1				
11	54-4939	TRIGGER SCREW	1				
12	54-4938	TRIGGER STUD	1				

▼ Also available as part of AA10 Conversion Kit 54-5302 (for converting AA1500 spray guns w/AA2 or AA4 air caps to AA1500 spray guns with AA10 air caps).

★ Only available as part of 54-5309 AA10 Retaining Ring Replacement Kit.

* Available as part of Repair Kit 54-4970.

■ Also available: 20-6037-K10 (Kit of 10 o-rings).

● Alternate fluid inlet fitting (18)—order separately.

▲ Alternate D.M. nipple (21) is included in gun package.

All O-rings are a minimum order qty. of 2.

AA1500 AIR-ASSISTED AIRLESS SPRAY GUN
PART NUMBER 1500-0000-10

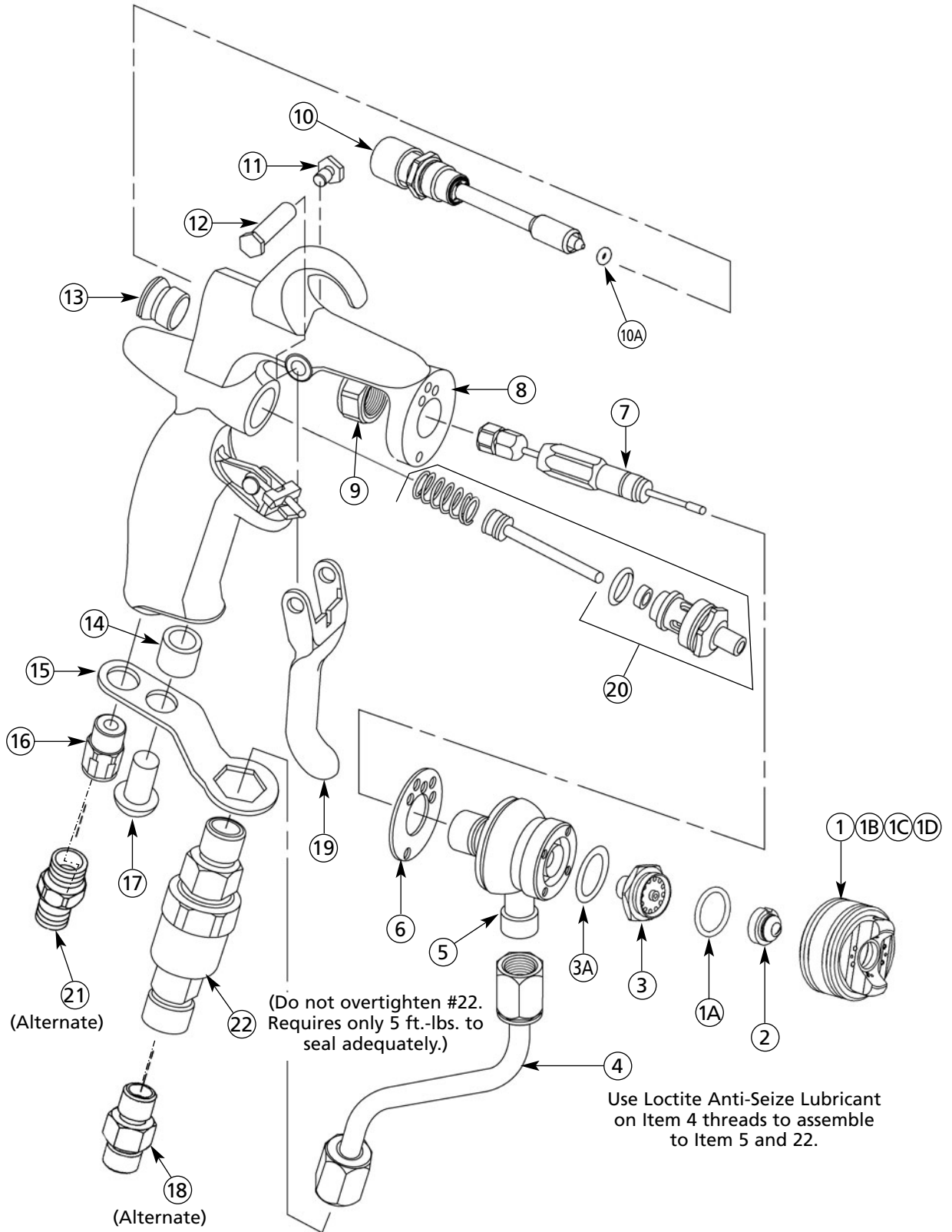

FLUID SEAT APPLICATION CHART

Carbide (Optional) 54-4960	UHMW (Standard) 54-4926
----------------------------	-------------------------

ACCESSORIES

HOSES	
71-4990	15' Polyurethane Air Tubing ASM w/fittings, 3/8" O.D., 1/4" I.D.
71-4991	25' Polyurethane Air Tubing ASM w/fittings, 3/8" O.D., 1/4" I.D.
71-4992	15' 1/8" High Pressure Fluid Hose Assembly
71-4993	25' 1/8" High Pressure Fluid Hose Assembly
71-4995	25' 3/16" Low Pressure (1900 PSI Max.) Fluid Hose Assembly
FITTINGS	
54-4975	1/8" NPT Male x 3/8" O.D. Push-In Tube Fitting (optional)
54-4976	1/4" NPT Female x 3/8" O.D. Push-In Tube Fitting (optional)
FLUID FILTER	
54-3655	100 Mesh (Element) Gun Mounted Filter, 5800 PSI w.p.
54-4725	100 Mesh (Element) Gun Mounted Filter, 4000 PSI w.p.
54-5010	100 Mesh (Screen) Gun Mounted Filter, 4000 PSI w.p.
REPLACEMENT FILTERS	
54-1835	Rplcmnt. Filter for Fluid Filters 54-3655 & 54-4725
54-5012-K10	Replacement Filter for Fluid Filter 54-5010
FLUID REGULATOR	
845001	Med. Press. Reg. w/Gauge, 6 gpm. 100 to 800 reg. range
845010	Med. Press. Reg. w/Gauge, 3 gpm. 400 to 1250 reg. range
CLEANING KIT	
54-4994	Cleaning Kit: Includes one standard stiff nylon pipe cleaning brush, full-size nylon brush, tip cleaner and Binks <i>Gunners Mate</i> lubricant.
TEST GAUGES	
54-5327	H.V.L.P. Test Gauge AA10

AA10 CONVERSION KIT

54-5302	Kit for converting AA1500 guns with AA2 air cap to AA1500 gun with AA10 air cap.
---------	--

Refer to page 6 for Repair Kits.

SPRAY TIP SELECTION CHARTS

Fan width based on 1000 PSI with water. Actual results may vary, depending on material viscosity.

PART NUMBER	DESCRIPTION	ORIFICE	FAN WIDTH (IN.)	GPM CAPACITY @500 PSI WATER
114-00702	TIP ASSEMBLY	.007	2	.028
114-00704	TIP ASSEMBLY	.007	4	.028
114-00706	TIP ASSEMBLY	.007	6	.028
114-00707	TIP ASSEMBLY	.007	8	.028
114-00902	TIP ASSEMBLY	.009	2	.039
114-00904	TIP ASSEMBLY	.009	4	.039
114-00906	TIP ASSEMBLY	.009	6	.039
114-00908	TIP ASSEMBLY	.009	8	.039
114-00910	TIP ASSEMBLY	.009	10	.039
114-00912	TIP ASSEMBLY	.009	12	.039
114-01104	TIP ASSEMBLY	.011	4	.060
114-01106	TIP ASSEMBLY	.011	6	.060
114-01108	TIP ASSEMBLY	.011	8	.060
114-01110	TIP ASSEMBLY	.011	10	.060
114-01112	TIP ASSEMBLY	.011	12	.060
114-01114	TIP ASSEMBLY	.011	14	.060
114-01304	TIP ASSEMBLY	.013	4	.090
114-01306	TIP ASSEMBLY	.013	6	.090
114-01308	TIP ASSEMBLY	.013	8	.090
114-01310	TIP ASSEMBLY	.013	10	.090
114-01312	TIP ASSEMBLY	.013	12	.090
114-01314	TIP ASSEMBLY	.013	14	.090
114-01316	TIP ASSEMBLY	.013	16	.090
114-01506	TIP ASSEMBLY	.015	6	.120
114-01508	TIP ASSEMBLY	.015	8	.120
114-01510	TIP ASSEMBLY	.015	10	.120
114-01512	TIP ASSEMBLY	.015	12	.120
114-01514	TIP ASSEMBLY	.015	14	.120
114-01516	TIP ASSEMBLY	.015	16	.120
114-01518	TIP ASSEMBLY	.015	18	.120
114-01706	TIP ASSEMBLY	.017	6	.160
114-01708	TIP ASSEMBLY	.017	8	.160
114-01710	TIP ASSEMBLY	.017	10	.160
114-01712	TIP ASSEMBLY	.017	12	.160
114-01714	TIP ASSEMBLY	.017	14	.160
114-01716	TIP ASSEMBLY	.017	16	.160
114-01718	TIP ASSEMBLY	.017	18	.160
114-01906	TIP ASSEMBLY	.019	6	.190
114-01908	TIP ASSEMBLY	.019	8	.190
114-01910	TIP ASSEMBLY	.019	10	.190
114-01912	TIP ASSEMBLY	.019	12	.190
114-01914	TIP ASSEMBLY	.019	14	.190
114-01916	TIP ASSEMBLY	.019	16	.190
114-01918	TIP ASSEMBLY	.019	18	.190
114-02110	TIP ASSEMBLY	.021	10	.240
114-02112	TIP ASSEMBLY	.021	12	.240
114-02114	TIP ASSEMBLY	.021	14	.240
114-02116	TIP ASSEMBLY	.021	16	.240
114-02118	TIP ASSEMBLY	.021	18	.240
114-02410	TIP ASSEMBLY	.024	10	.310
114-02412	TIP ASSEMBLY	.024	12	.310
114-02414	TIP ASSEMBLY	.024	14	.310
114-02416	TIP ASSEMBLY	.024	16	.310
114-02418	TIP ASSEMBLY	.024	18	.310
114-02710	TIP ASSEMBLY	.027	10	.385
114-02712	TIP ASSEMBLY	.027	12	.385
114-02714	TIP ASSEMBLY	.027	14	.385
114-02716	TIP ASSEMBLY	.027	16	.385
114-02718	TIP ASSEMBLY	.027	18	.385

Binks Worldwide Sales and Service Listing: www.binks.com

ITW Industrial Finishing

Binks has authorized distributors throughout the world. For technical assistance or the distributor nearest you, see listing below.

U.S./Canada Technical Service Office:

195 Internationale Blvd., Glendale Heights, IL 60139
Toll-Free Telephone: 1-888-992-4657 (U.S.A. and Canada only)
Toll-Free Fax: 1-888-246-5732

WARRANTY

This product is covered by Binks' 1 Year Limited Warranty.

77-2838R-2 Revisions: (P2) Replaced warnings page.



An Illinois Tool Works Company