

# Binks Pogo Plus Bung Mount 2:1 Piston Pump

**BINKS®**  
A41-87R 4/04

*Ideally suited  
for high-volume  
delivery of  
low-medium  
viscosity coatings  
or adhesives*

**POGO**  
*Plus*

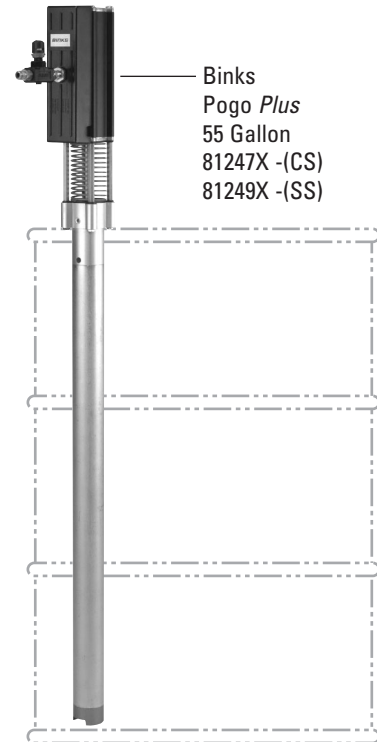

## **Binks Pogo Plus Bung Mount 2:1 Piston Pump**

Binks Pogo Plus series, two-ball, double acting piston pumps are designed for the application and transfer of low-medium viscosity fluids. Models are available in Stainless Steel or Carbon Steel. Both the 55 gallon and stubby version of each pump are offered with either Teflon™ or UHMWPE dynamic seals. This affords the user a selection that will be compatible with a wide variety of materials which includes water or solvent borne paints and adhesives and with most solvents. The two-ball design provides better priming of the foot-valve. Double acting pumps will deliver material on both the up and down stroke.

### **Markets and Applications**

Wood Cabinets, Countertops, Furniture Upholstery, Truck and Bus, Laminates use for adhesives application. HVAC use for applying adhesive inside ducts. Marine, Boat, Tub and Shower use for fluid transfer. Foam Insulation use for solvent supply for 2K equipment. General Industry use for single gun paint supply.

### **Features**

- Production-proven 2" air motor with 3" stroke
- Stainless steel or carbon steel construction for a wide range of solvent or water-borne materials
- UHMW or teflon cup/packing sets availability
- Divorced design for easy maintenance
- Drum and stubby versions depending on your application
- Delivers generous 2.15 gpm @ 60 cycles/min.
- Includes air inlet and fluid outlet fittings

### **Specifications**

Type-All Models . . . . .	Air Operated, 2-Ball
Ratio-All Models . . . . .	2:1
Air Motor . . . . .	842010 All Models
Motor Repair Kit . . . . .	861150
Lower Pump Repair Kit (SS) . . . . .	86114X
Lower Pump Repair Kit (CS) . . . . .	86113X
Motor Diameter . . . . .	2" (5.08 cm)
Stroke (Double Acting) . . . . .	3" (7.62 cm)
Air Inlet (with fittings) -All Pumps . . . . .	1/4" NPS (m)
Material Inlet -(SS) Stubby Pumps . . . . .	1-1/4" NPT (f)
Material Inlet -(CS) Stubby Pumps . . . . .	1-1/2" NPT (f)
Material Inlet -All 55 Gallon Drum Pumps . . . . .	No threads, pump is immersed
Material Outlet (with fittings) -All Pumps . . . . .	3/8" NPS (m)

### **Shipping Weights**

812470, 812471 55 Gal. – CS . . . . .	19.6 lbs. (8.9 kg)
812480, 812481 Stub – CS . . . . .	17.5 lbs. (7.9 kg)
812490, 812491 55 Gal. – SS . . . . .	22.5 lbs. (10.2 kg)
812500, 812501 Stub – SS . . . . .	17.2 lbs. (7.8 kg)

SS = Stainless Steel, CS = Carbon Steel

**Refer to Service Bulletin:**  
**81249X SS, 81247X CS**

# Binks Pogo Plus Bung Mount 2:1 Piston Pump

## Description

PART NUMBER	DESCRIPTION AND CONSTRUCTION	PACKING U & L
812470	NEW! 2" 2:1 POGO (CS) 55 Gal.	UHMW-PE
812471	Replaces 812302 2" 2:1 POGO (CS) 55 Gal.	Teflon
812490	Replaces 812300 2" 2:1 POGO (SS) 55 Gal.	UHMW-PE
812491	NEW! 2" 2:1 POGO (SS) 55 Gal.	Teflon
PART NUMBER	DESCRIPTION AND CONSTRUCTION	PACKING U & L
812480	NEW! 2" 2:1 POGO (CS) Stubby	UHMW-PE
812481	NEW! 2" 2:1 POGO (CS) Stubby	Teflon
812500	Replaces 812304 2" 2:1 POGO (SS) Stubby	UHMW-PE
812501	NEW! 2" 2:1 POGO (SS) Stubby	Teflon

## Performance – All Models

Air Inlet Pressure ..... 0-150 psi (0-10.3 bar)  
 Fluid Pressure Range ..... 0-300 psi (0-24.2 bar)  
 Max. Recommended Cycles/Min. .... 120  
 Displacement per Cycle ..... 8.28 cubic inches  
 Volume per Cycle ..... 4.59 oz. (135.6 ml)  
 Cycles per Gallon ..... 27.9  
 Flow @ 60 Cycles/Minute ..... 2.15 gpm (8.14 lpm)  
 Noise Level @ 100psi ..... 80 db(A)

## Available Accessories

Air Control ..... 41-15931  
 Muffler ..... 873191  
 Wall Mount or Open Drum Mount Bracket .... 873184

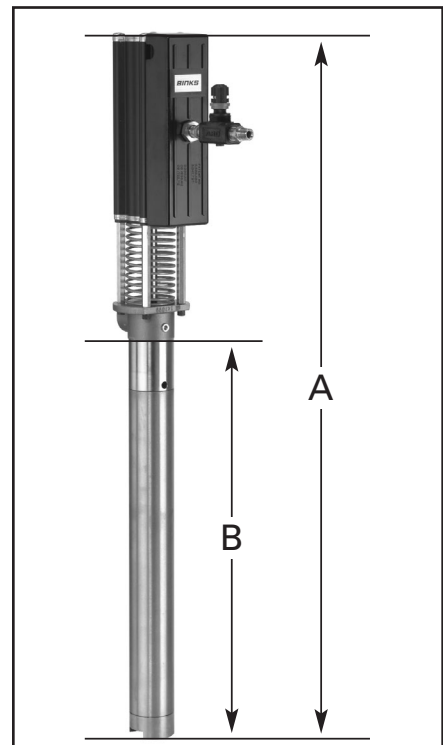

## Dimensional Data

MODEL	A (mm)	B (mm)	Weight (kg)
81247X●	47-7/8" (1214.8)	33-11/16" (855.6)	19.6 (8.9)
81248X▲	34-3/16" (868.0)	20-1/16" (508.8)	17.5 (7.9)
81249X●	47-3/4" (1211.8)	33-11/16" (855.6)	22.5 (10.2)
81250X▲	33-7/8" (859.9)	19-7/8" (503.7)	17.2 (7.8)

Capacity: ● 55 Gal. ▲ 5 Gal.

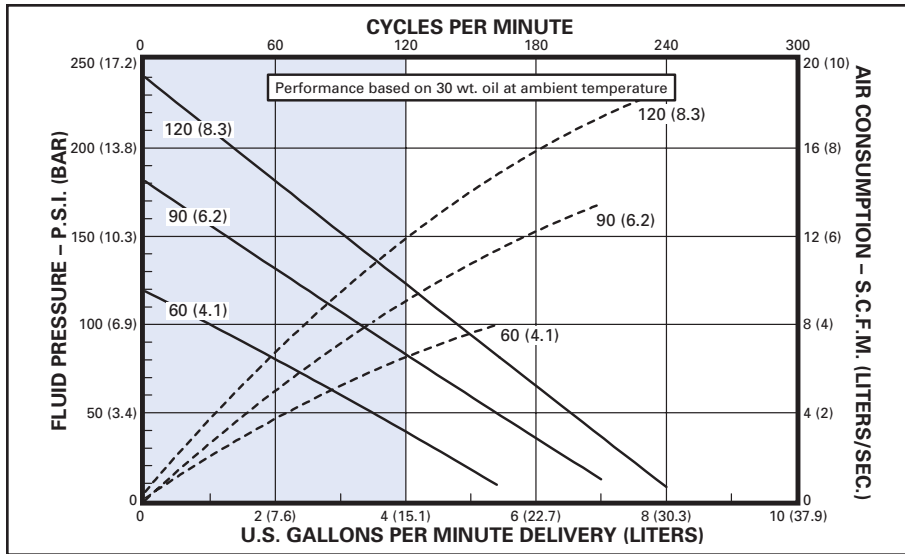

## Pogo Plus Spray Finishing Adhesive Outfit Model 98-3061

### General Description

This (55) gallon bung system is complete with 2001 SS gun w/66SS x 66SD-3 set-up, 2:1 ratio supply pump with air control and 25 ft. fluid and air hose assemblies.

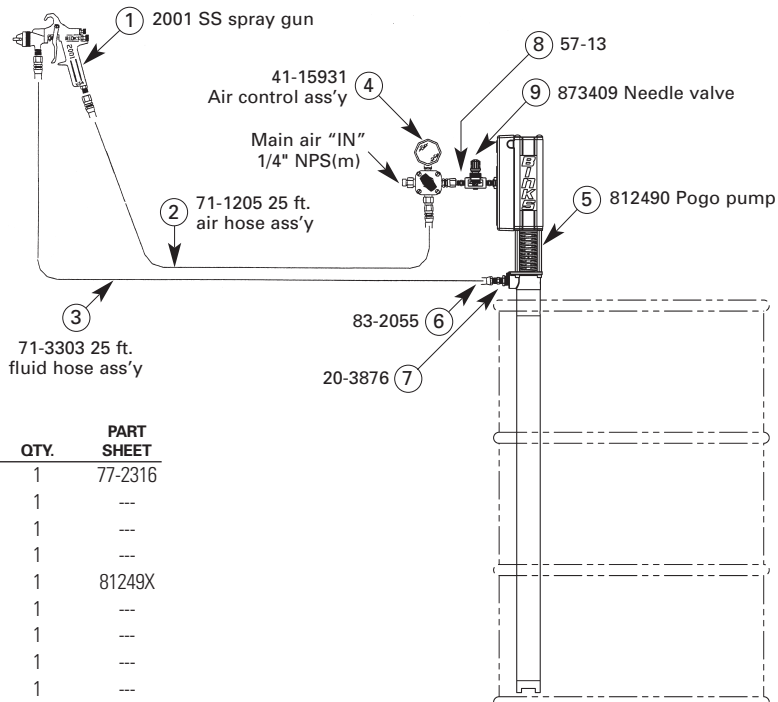

ITEM NO.	PART NO.	DESCRIPTION	QTY.	PART SHEET
1	6215-4308-2	2001 SS gun 66SS x 66SD-3	1	77-2316
2	71-1205	25' Air Hose Ass'y	1	---
3	71-3303	25' Fluid Hose Ass'y	1	---
4	41-15931	Air Control Ass'y	1	---
5	812490	SS Pogo Pump Pkg	1	81249X
6	83-2055	SS DM Nipple	1	---
7	20-3876	Bushing	1	---
8	57-13	DM Nipple	1	---
9	873409	Needle Valve	1	---



195 Internationale Blvd.  
 Glendale Heights, IL 60139

630-237-5000  
 Fax 630-237-5003  
 www.binks.com